



New Zealand Gazette

WELLINGTON: THURSDAY, 3 APRIL 2008

CONTENTS

COMMERCIAL

Bankruptcy Notices	1886
Company Notices —	
Appointment and Release of Receivers / Managers	1887
Appointment and Release of Liquidators	1888
Appointment and Release of Administrators	None
Meetings and Last Dates by Which to Prove Debts or Claims	1895
Removals	1895
Cessation of Business in New Zealand	1900
Applications for Winding Up / Liquidations	1900
Partnership Notices	None
Other	1907
Land Transfer / Joint Family Homes Notices	None

Charitable Trusts Notices	None
Friendly Societies and Credit Unions Notices	None
Incorporated Societies Notices	None
General Notices	1908

GOVERNMENT

Vice Regal	1908
Parliamentary Notices	None
Departmental Notices	1908
Authorities and Other Agencies of State Notices	1915
Land Notices	1917
Regulation Summary	1922
General Section	1922
Deadlines	1932
Index	1932

USING THE GAZETTE

The *New Zealand Gazette*, the official newspaper of the Government of New Zealand, is published weekly on Thursday. Publishing time is 4.00pm.

Closing time for lodgement of notices under the Companies, Partnership, Insolvency and Land Transfer Acts is 12.00 midday on Monday (except where that day is a public holiday, in which case the deadline will be 12.00 midday on the last working day of the preceding week).

All other notices must be lodged at the *New Zealand Gazette* office by 12.00 midday, Tuesday, in the week of publication.

Notices are accepted for publication in the next available issue, unless otherwise specified.

Notices may be submitted by email, facsimile or post. Dates and proper names should be shown clearly.

A covering instruction setting out requirements should accompany all notices, but the *New Zealand Gazette* reserves the right to apply its in-house style.

Notices for publication and related correspondence should be addressed to

New Zealand Gazette
 Department of Internal Affairs
 PO Box 805
 Wellington
 Telephone: (04) 470 2930 / (04) 470 2931
 Facsimile: (04) 470 2932
 Email: gazette@parliament.govt.nz



Cancelled Notices

Notices cancelled after being accepted for publication will be subject to a charge of \$55.00 to cover setting up and deleting costs. The deadline for cancelling notices is 12.00 midday on Wednesdays.

Advertising Rates

The following rate applies for the insertion of all notices in the *New Zealand Gazette*: 50c per word/number.

Customers will be invoiced in accordance with standard commercial practices.

Advertising rates are not negotiable.

All rates shown are inclusive of GST.

Other editions of the *New Zealand Gazette*

Customs Edition – Published weekly on Tuesday.

Special Editions, Professional & Trade Lists and *Supplements* – Published as and when required.

Availability

New Zealand Gazette editions and a search-by-notice facility are available on the website

www.gazette.govt.nz

All editions are also available on subscription from the New Zealand Gazette Office, Department of Internal Affairs, PO Box 805, Wellington (telephone: (04) 470 2930), or over the counter at

Bennetts Government Bookshop, Bowen House, Lambton Quay, Wellington.

Copyright

© The *New Zealand Gazette* is subject to Crown copyright.

For more information visit

www.gazette.govt.nz

Bankruptcy Notices

Bankruptcies

The official assignee advises the following bankruptcies:

Bird, Daniel, 127 Pukepoto Road, Kaitaia – 20 March 2008.

Bishop, Jason, 1 Sollum Road, Panmure, Auckland – 19 March 2008.

Brown, Shane, 72 Pukenamu Road, Te Horo, Wellington – 25 March 2008.

Cockayne, Paul, Zane Grey Resort, Urupukapuka Island, Bay of Islands – 17 March 2008.

Cross, Norm, 21 Barlow Place, Chatswood, North Shore City – 19 March 2008.

Dalrymple-Wilson, Robert (also known as **Wilson, BJ**), 537 Gloucester Street, Linwood, Christchurch – 20 March 2008.

Elliott, Warren, 803A Kennedy Road, Ruareka, Hastings – 27 March 2008.

Forde, Michael, 37 Everard Avenue, Army Bay – 27 March 2008.

Green, Daniel, 5/62 Bowmont, Street, Invercargill – 26 March 2008.

Hansen, Pamela, 22 Shortland Street, Tamatea, Napier – 27 March 2008.

Hocking, Anthony, 385 St Georges Road, Havelock North – 27 March 2008.

Hocking, Deborah, 385 St Georges Road, Havelock North – 27 March 2008.

Jones, Natalie, 2/82 Buckingham Street, Richmond, Melbourne, Victoria, Australia – 27 March 2008.

Joyce, Carolyn, 68 Devon Street, Arrowtown – 27 March 2008.

Kanongata'a, Siaosi (also known as **Kanongata'a, George**), 35 Wimbledon Crescent, Glen Innes, Auckland – 26 March 2008.

Marinus, Wiebe, 9B Rata Street, Hataitai, Wellington – 17 March 2008.

Martin, William, 1878 State Highway 29, RD 1, Lower Kaimai, Tauranga – 26 March 2008.

Mayer, Shannon-Lee, 54 Tiger Drive, Golflands, Auckland – 26 March 2008.

Priest, Brent, 153 Stockman Road, RD 43, Tikorangi – 20 March 2008.

Radovanovich, Ross, 23 Javelin Street, Runcorn, Brisbane, Queensland, Australia – 19 March 2008.

Savage, Christine (also known as **Noyce, Christine**), 14/1 Kereru Grove, Stokes Valley, Lower Hutt – 26 March 2008.

Sheppard, Brent, Ararua Road, RD 2, Matakohe – 17 March 2008.

Sheppard, Elana, Ararua Road, RD 2, Matakohe – 17 March 2008.

Simon, Dawn, 44 Hirangi Road, Turangi – 12 March 2008.

Simon, Stanley, 41 Hirangi Road, Turangi – 12 March 2008.

Stace, Carolyn, 1/110 Aorangi Road, Bryndwr, Christchurch – 27 March 2008.

Stevenson, Craig, 68 Devon Street, Arrowtown – 27 March 2008.

Stewart, Bridget, 23 Javelin Street, Runcorn, Brisbane, Australia – 19 March 2008.

Tane, Paul, 372 Waikino Road, Kawakawa – 17 March 2008.

Tang and Sirisomphone Partnership, 142 Kitchener Road, Milford, Auckland – 11 March 2008.

Te Tai, Fiona, 372 Waikino Road, Kawakawa – 17 March 2008.

Wastney, Lisa, 143 Limeworks Road, Waikari, North Canterbury – 25 March 2008.

Watson, Helen, 4B Langstone Street, Welcome Bay, Tauranga – 19 March 2008.

OFFICIAL ASSIGNEE.

Private Bag 4714, Christchurch. Freephone: 0508 467 658.

Website: www.insolvency.govt.nz

ba2133

No Asset Procedures

The official assignee advises the following no asset procedures:

Benade, Tahlita, 21 Worcester Street, Awapuni, Palmerston North – 26 March 2008.

Carter, Ron, 25 Ross Street, Onerahi, Whangarei – 19 March 2008.

Charrington, Emma (also known as **Allan, Emma**), 900 Old Coach Road, RD 6, Te Puke – 19 March 2008.

Downing, David John, Lot 56, 16 Beach Haven Place, Paraparaumu – 27 March 2008.

Fahey, David, 1/52 Harvey Terrace, Richmond, Christchurch – 25 March 2008.

Fifita, Taione, 3/15 Kentucky Street, Ellerslie, Auckland – 19 March 2008.

Fraser, Valerie, 7/40 Bristol Street, St Albans, Christchurch – 19 March 2008.

Geoghegan, Eileen (also known as **Pascall, Gwenneth**), 8A Simcox Street, Otaki – 26 March 2008.

Houghton, Tracey (also known as **Beale, Tracey**), 142 Lower Durham Road, RD 8, Inglewood – 19 March 2008.

Johnston, Tinaya Lee (also known as **Enoka, Tinaya**), Flat 3, 94 Hokianga Road, Dargaville – 25 March 2008.

Jones, Allison, 75 Tedder Avenue, North Beach, Christchurch – 26 March 2008.

Joyce, Andrea (also known as **Meads, Andrea** and **Joyce-Meads, Andrea**), 5 Midhurst Street, Bishopdale, Christchurch – 26 March 2008.

Just, Joshua, 460 Dee Street, Avenal, Invercargill – 20 March 2008.

Keene, Kirstyn, 29 Gilliam Street, New Lynn, Auckland – 19 March 2008.

Malloch, Katrina, 12 Steven Street, Mangere East, Auckland – 27 March 2008.

Marsh, Katarina, 121A Clevedon Road, Papakura, Auckland – 26 March 2008.

Marshall, Brenda, 85 Kiwi Esplanade, Mangere Bridge, Auckland – 26 March 2008.

Nodder, Russal, 41 Taylor Terrace, St Andrews, Hamilton – 25 March 2008.

Olo'apu, Mary (also known as **Harris, Mary**), 12B Wing Crescent, Papakura, Auckland – 27 March 2008.

Pain, Joshua, 141 Elizabeth Street, Tauhara, Taupo – 27 March 2008.

Paton, Briar-Rose, 2/5 Marma Street, Frankton, Hamilton – 20 March 2008.

Patterson, Nikita, 72 Pukenamu Road, Te Horo, Wellington – 20 March 2008.

Rudolph, Maureen, 39 May Road, Mt Roskill, Auckland – 19 March 2008.

Smith, Karen, 3 Arney Street, Dunedin – 26 March 2008.

Smith, Maeve (also known as **Watkins-Smith, Libby** and **Smith, Libby**), 10 Keats Place, Whalers Gate, New Plymouth – 20 March 2008.

Smith, Trevor, 3 Arney Street, Dunedin – 26 March 2008.

Vakaruru, Loraini, 13/116 Wellington Street, Freemans Bay, Auckland – 19 March 2008.

Walker, Sandra, 24 Bellbrook Crescent, Shirley, Christchurch – 20 March 2008.

Warren, Gayle, 283B Stokes Valley Road, Stokes Valley, Lower Hutt – 26 March 2008.

Whibley, Krystina, 31 Judd Crescent, Naenae, Lower Hutt – 19 March 2008.

Wilkinson, Matthew, 181 Somme Parade, Aramoho, Wanganui – 27 March 2008.

Witoku, Christine (also known as **Plant, Christine**), Rotorua – 25 March 2008.

OFFICIAL ASSIGNEE.

Private Bag 4714, Christchurch. Freephone: 0508 467 658.
Website: www.insolvency.govt.nz

ba2134

Company Notices

APPOINTMENT AND RELEASE OF RECEIVERS / MANAGERS

Advantage Construction & Consultancy Limited
(in receivership) (“the company”)

Notice of Appointment of Replacement Receivers

Pursuant to Section 8(2) of the Receiverships Act 1993

Company No.: 1032156

Colin Thomas McCloy and John Anthony Waller, of PricewaterhouseCoopers, were appointed joint and several receivers of Advantage Construction & Consultancy Limited on 14 March 2008, in place of Anthony John McCullagh and Stephen Mark Lawrence, of Horwath Corporate (Auckland) Limited, under the terms of a security agreement dated the 22nd day of July 2002.

The Property in Receivership is: All of the company's undertaking, property and assets.

The Receivers' Office Address is and Enquiries May be Directed to: PricewaterhouseCoopers, Level 8, PricewaterhouseCoopers Tower, 188 Quay Street (Private Bag 92162), Auckland. Telephone: (09) 355 8000. Facsimile: (09) 355 8013.

Dated this 14th day of March 2008.

COLIN THOMAS MCCLOY, Receiver.

Danben Holdings Limited (trading as **The Meetings**)
(in receivership)

Notice of Appointment of Receivers and Managers

Pursuant to Section 8 of the Receiverships Act 1993

We advise that on 26 March 2008, Boris van Delden and John Trevor Whittfield, insolvency practitioners of Auckland, were appointed jointly and severally as receivers and managers of the property of Danben Holdings Limited under the powers contained in a general security agreement dated the 5th day of September 2003, which property consists of all of the company's present and after acquired personal property.

Office of the Receivers and Managers is: C/o McDonald Vague, 5th Floor, 80 Greys Avenue, Auckland.
Telephone: (09) 303 0506. Facsimile: (09) 303 0508.
Website: www.mvp.co.nz

Dated this 26th day of March 2008.

BORIS VAN DELDEN, Receiver and Manager.

ar2104



APPOINTMENT AND RELEASE OF LIQUIDATORS

Appointment of Liquidator

The official assignee advises the following liquidation:

19 March 2008

Wairarapa Financial Services Limited.

OFFICIAL ASSIGNEE.

Private Bag 4714, Christchurch. Freephone: 0508 467 658.
Website: www.insolvency.govt.nz

al2135

Iso Vines Limited (in liquidation)

Notice of Appointment of Liquidator

Pursuant to Section 255(2) of the Companies Act 1993

Christine Margaret Dunphy was appointed as liquidator of the company pursuant to a special resolution of shareholders entered into the company's minute book, under section 241(2)(a) of the Companies Act 1993, on the date and time below:

28 March 2008

Iso Vines Limited (in liquidation) at 10.50am.

Dated at Wellington this 29th day of March 2008.

CHRIS DUNPHY, Liquidator.

Address for Service: Shephard Dunphy Limited, Level 2, Zephyr House, 82 Willis Street, Wellington. Telephone: (04) 473 6747. Facsimile: (04) 473 6748.

Postal Address for Service: Shephard Dunphy Limited, PO Box 11793, Wellington.

For Enquiries Contact: Jayme Dixon.

Note: This liquidation is for the purpose of restructuring the affairs of the shareholders.

al2188

The Companies Act 1993

Top Laminators Limited (in liquidation) at 4.40pm.

PS Property Botany Downs Limited at 4.30pm.

Zanado Enterprises Limited (in liquidation) at 4.20pm.

Auckland City Lease Limited (in liquidation) at 4.35pm.

PS Property New Lynn Limited at 4.15pm.

BSR Limited (in liquidation) at 4.10pm.

PS Property Holdings Limited at 4.00pm.

Pacific Properties (PS No.1) Limited at 5.00pm.

Auckland City Lease Holdings Limited (in liquidation) at 4.45pm.

Livewell 2004 Limited (in liquidation) at 4.55pm.

The above-named solvent companies were placed into liquidation by resolutions of shareholders and have ceased trading, disposing of their assets.

Notice of Appointment of Liquidator

Robert John Willis, of CST Nexia Limited, Chartered Accountants, was appointed liquidator of the above-named companies on 20 March 2008 at the times specified, pursuant to section 241(2)(a).

Notice to Creditors to Prove Debts or Claims

Notice is given that the liquidator fixes 15 April 2008, as the day on or before which the creditors of each company are to make their claims and to establish any priority their claims may have, under section 312, or to be excluded from the benefit of any distribution made before the claims are made or, as the case may be, from objecting to the distribution.

Notice of Intention to Remove

Application to remove the above-named companies will be made to the Registrar, pursuant to section 318(1)(e), on the grounds that the documents referred to in section 257(1)(a) will be sent to the Registrar after 22 working days from the date of this notice. Objections to remove, under section 321, must be delivered to the Registrar within that period.

Dated this 20th day of March 2008.

ROBERT JOHN WILLIS, Liquidator.

The Address and Telephone Number to Which, During Normal Business Hours, Enquiries May be Directed by a Creditor or Member: CST Nexia Limited, Chartered Accountants, PO Box 76261, Manukau City. Telephone: (09) 262 2595.

al2082

Westway Quarry Limited (in liquidation)

Public Notice of Appointment of Liquidator

Pursuant to Section 255(2)(a) of the Companies Act 1993

On 31 March 2008, it was resolved by special resolution of shareholders, pursuant to section 241(2)(a) of the Companies Act 1993, that Westway Quarry Limited be liquidated and that Jugdis Hira Parbhu, chartered accountant of Ross Melville PKF, be appointed liquidator for the purpose.

The liquidation commenced on 31 March 2008.

Liquidator's Section 245 Notice to Creditors

To all known creditors:

Notice is hereby given by the liquidator, pursuant to section 245(1)(b) of the Companies Act 1993, that:

1. The liquidator does not consider that a meeting of creditors should be called for the purpose specified in section 243(1)[(a)][(b)] of the Companies Act 1993.
2. The reason why the liquidator so decided is the company is solvent.
3. No such meeting will therefore be called unless a creditor gives notice in writing to the liquidator, within 10 working days after receiving this notice, requiring a meeting to be called.

Creditors and shareholders may direct enquiries to me during normal business hours at the address and contact numbers stated below.

Dated this 3rd day of April 2008.

JUGDIS HIRA PARBHU, Liquidator.

Address of Liquidator: 2B William Pickering Drive, North Harbour, Auckland. Telephone: (09) 414 1200. Facsimile: (09) 414 1920.

al2185

Hong Kong Cuisine Cafe Limited (in liquidation)

Notice of Appointment of Liquidators

Pursuant to Section 255(2)(a) of the Companies Act 1993

Rachel Mason and Jeffrey Philip Meltzer, insolvency practitioners, were appointed joint and several liquidators of Hong Kong Cuisine Cafe Limited (in liquidation) on 20 March 2008 at 10.30am, pursuant to section 241(2)(a) of the Companies Act 1993.

Notice to Creditors to Prove Debts or Claims

Notice is given that the liquidators of Hong Kong Cuisine Cafe Limited (in liquidation) fix 25 April 2008, as the day on or before which the creditors of the company are to make their claims and to establish any priority their claims may

have, under section 312 of the Companies Act 1993, or to be excluded from the benefit of any distribution made before their claims are made or, as the case may be, from objecting to any distribution.

Dated this 20th day of March 2008.

R. K. MASON, Liquidator.

The Address and Contact Numbers to Which, During Normal Business Hours, Enquiries May be Directed by a Creditor or Member: Meltzer Mason Heath, Chartered Accountants, PO Box 6302, Wellesley Street, Auckland 1141. Telephone: (09) 357 6150. Facsimile: (09) 357 6152.

Enquiries to: Rachel Mason.

Note: The shareholders of Hong Kong Cuisine Cafe Limited (in liquidation) wish to liquidate the above-named company as the business has been sold. This liquidation has no connection to the business continuing to operate under this name or any similar name.

al2084

EmbeddedFusion Limited (in liquidation)

Notice of Appointment of Liquidators

Pursuant to Section 255(2)(a) of the Companies Act 1993

Jeffrey Philip Meltzer and Michael Lamacraft, insolvency practitioners, were appointed joint and several liquidators of EmbeddedFusion Limited (in liquidation) on 25 March 2008 at 9.00am, pursuant to section 241(2)(a) of the Companies Act 1993.

Notice to Creditors to Prove Debts or Claims

Notice is given that the liquidators of EmbeddedFusion Limited (in liquidation) fix 25 April 2008, as the day on or before which the creditors of the company are to make their claims and to establish any priority their claims may have, under section 312 of the Companies Act 1993, or to be excluded from the benefit of any distribution made before their claims are made or, as the case may be, from objecting to any distribution.

Dated this 27th day of March 2008.

M. LAMACRAFT, Liquidator.

The Address and Contact Numbers to Which, During Normal Business Hours, Enquiries May be Directed by a Creditor or Member: Meltzer Mason Heath, Chartered Accountants, PO Box 6302, Wellesley Street, Auckland 1141. Telephone: (09) 357 6150. Facsimile: (09) 357 6152.

Enquiries to: Mike Lamacraft.

al2111

WXY Limited (in liquidation)

Notice of Appointment of Liquidators

Pursuant to Section 255(2)(a) of the Companies Act 1993

Jeffrey Philip Meltzer and Lloyd James Hayward, insolvency practitioners, were appointed joint and several liquidators of WXY Limited (in liquidation) on 27 March 2008 at 10.00am, pursuant to section 241(2)(a) of the Companies Act 1993.

Notice to Creditors to Prove Debts or Claims

Notice is given that the liquidators of WXY Limited (in liquidation) fix 28 April 2008, as the day on or before which the creditors of the company are to make their claims and to establish any priority their claims may have, under section 312 of the Companies Act 1993, or to be excluded from the benefit of any distribution made before their claims are made or, as the case may be, from objecting to any distribution.

Dated this 27th day of March 2008.

L. J. HAYWARD, Liquidator.

The Address and Contact Numbers to Which, During Normal Business Hours, Enquiries May be Directed by a Creditor or Member: Meltzer Mason Heath, Chartered Accountants, PO Box 6302, Wellesley Street, Auckland 1141. Telephone: (09) 357 6150. Facsimile: (09) 357 6152.

Enquiries to: Rachel Mason.

al2126

Pacific Carwash Systems Limited (in liquidation)

Notice of Appointment of Liquidators

Pursuant to Section 255(2)(a) of the Companies Act 1993

Notice is given that on 27 March 2008 at 10.00am, a special resolution was passed by the shareholders stating that the company be wound up voluntarily and Karen Betty Mason and Jeffrey Philip Meltzer be appointed as liquidators.

A solvency certificate has been filed in accordance with section 243(9) of the Companies Act 1993.

Notice to Creditors to Prove Debts or Claims

Notice is given that the liquidators of Pacific Carwash Systems Limited (in liquidation) fix 28 April 2008, as the day on or before which the creditors of the company are to make their claims and to establish any priority their claims may have, under section 312 of the Companies Act 1993, or to be excluded from the benefit of any distribution made before their claims are made or, as the case may be, from objecting to the distribution.

Dated this 28th day of March 2008.

K. B. MASON, Liquidator.

The Address and Contact Numbers to Which, During Normal Business Hours, Enquiries May be Directed by a Creditor or Member: Meltzer Mason Heath, Chartered Accountants, PO Box 6302, Wellesley Street, Auckland 1141. Telephone: (09) 357 6150. Facsimile: (09) 357 6152.

Enquiries to: Rachel Mason.

Explanation: The shareholders of Pacific Carwash Systems Limited (in liquidation) wish to liquidate the above-named solvent company which is no longer trading. The company sold its business to Pacific Carwash Systems (2008) Limited, which is currently operating the business and is in no way connected to the company in liquidation.

al2154

OVL Builders Limited (in liquidation)

Notice of Appointment of Liquidators

Notice is hereby given that, pursuant to section 241(2)(a) of the Companies Act 1993, Richard Grant Simpson and David Ian Ruscoe, chartered accountants of Grant Thornton, were appointed liquidators of OVL Builders Limited.

The liquidation commenced on 20 March 2008 at 2.00pm.

The directors have resolved that the company is solvent and will be able to pay its debts.

A copy of that resolution has been delivered to the Registrar of Companies pursuant to section 243(8) of the Companies Act 1993.

Notice to Creditors to Prove Debts or Claims

Notice is also given that the liquidators hereby fix 8 April 2008, as the date on or before which the creditors of the company are to make their claims and to establish any priority their claims may have, under section 312 of the Companies Act 1993, or to be excluded from the benefit of any distribution made before their claims are made or, as the case may be, from objecting to any distribution.

Enquiries may be directed during normal business hours to Andy Bitchener, Grant Thornton, Level 13, AXA Building, 80 The Terrace (PO Box 10712), Wellington. Telephone: (04) 474 8500.

Dated this 20th day of March 2008.

RICHARD GRANT SIMPSON.

Note: The company is solvent and is being liquidated as it has completed the purpose for which it was incorporated.

al2063

Black Rocks Cafe and Bar Limited (in liquidation)

Notice of Appointment of Liquidators

John Howard Ross Fisk, chartered accountant, and Craig Alexander Sanson, insolvency practitioner, both of Wellington, were appointed joint and several liquidators of Black Rocks Cafe and Bar Limited by the High Court, pursuant to section 241(2)(c) of the Companies Act 1993, on 26 March 2008 at 10.28am.

Notice to Creditors to Claim

Notice is given that as liquidators of Black Rocks Cafe and Bar Limited, we fix 26 May 2008, as the day on or before which the creditors of the company are to make their claims and to establish any priority their claims may have, under section 312 of the Companies Act 1993, or to be excluded from the benefit of any distribution made before the debts are claimed or, as the case may be, from objecting to the distribution.

Dated this 27th day of March 2008.

CRAIG ALEXANDER SANSON, Liquidator.

Claims Are to be Forwarded and Creditors and Shareholders May Direct Enquiries to: Black Rocks Cafe and Bar Limited (in liquidation), c/o PricewaterhouseCoopers, 113–119 The Terrace (PO Box 243), Wellington. Telephone: (04) 462 7489. Facsimile: (04) 462 7492 (*Attention:* Sandra Pearson).

al2122

Foxton Hotel Limited (in liquidation)

Notice of Appointment of Liquidators

John Howard Ross Fisk, chartered accountant, and Craig Alexander Sanson, insolvency practitioner, both of Wellington, were appointed joint and several liquidators of Foxton Hotel Limited by the High Court, pursuant to section 241(2)(c) of the Companies Act 1993, on 28 March 2008 at 9.51am.

Notice to Creditors to Claim

Notice is given that as liquidators of Foxton Hotel Limited, we fix 27 May 2008, as the day on or before which the creditors of the company are to make their claims and to establish any priority their claims may have, under section 312 of the Companies Act 1993, or to be excluded from the benefit of any distribution made before the debts are claimed or, as the case may be, from objecting to the distribution.

Dated this 28th day of March 2008.

CRAIG ALEXANDER SANSON, Liquidator.

Claims Are to be Forwarded and Creditors and Shareholders May Direct Enquiries to: Foxton Hotel Limited (in liquidation), c/o PricewaterhouseCoopers, 113–119 The Terrace (PO Box 243), Wellington. Telephone: (04) 462 7044. Facsimile: (04) 462 7492 (*Attention:* Carl P. Messerschmidt).

al2173

Benton Rede Limited

Notice of Appointment of Liquidator

On 28 March 2008, the shareholders of the above-named company passed a special resolution that the company be placed into liquidation, having filed a resolution as to solvency pursuant to sections 243(8) and 243(9) of the

Companies Act 1993, and that Neville Petrie Fagerlund, chartered accountant, be appointed liquidator.

Notice to Creditors to Claim

Pursuant to Regulation 12 of the Companies Act 1993 Liquidation Regulations 1994

Notice is also given that I hereby fix 4 May 2008, as the day on or before which the creditors of the company are required to make their claims and to establish any priority their claims may have under section 312 of the Act.

N. P. FAGERLUND.

Address of Liquidator: C/o HFK Limited, PO Box 5071, Papanui, Christchurch. Telephone: (03) 352 9189.

Please Note: The above is part of a restructuring process and all creditors have or will be paid in full.

al2160

Thunder Holdings Limited

Notice of Appointment of Liquidator

On 28 March 2008, the shareholders of the above-named company passed a special resolution that the company be placed into liquidation, having filed a resolution as to solvency pursuant to sections 243(8) and 243(9) of the Companies Act 1993, and that Neville Petrie Fagerlund, chartered accountant, be appointed liquidator.

Notice to Creditors to Claim

Pursuant to Regulation 12 of the Companies Act 1993 Liquidation Regulations 1994

Notice is also given that I hereby fix 4 May 2008, as the day on or before which the creditors of the company are required to make their claims and to establish any priority their claims may have under section 312 of the Act.

N. P. FAGERLUND.

Address of Liquidator: C/o HFK Limited, PO Box 5071, Papanui, Christchurch. Telephone: (03) 352 9189.

Please Note: The above is part of a restructuring process and all creditors have or will be paid in full.

al2161

Transport Repairs & Services 2002 Limited

Public Notice of Appointment of Liquidator

The Companies Act 1993

On 28 March 2008, it was resolved by special resolution, pursuant to section 241 of the Companies Act 1993, that Transport Repairs & Services 2002 Limited be liquidated and that Bruce Donald Gemmell, chartered accountant of Christchurch, be appointed as liquidator for the purpose.

The liquidation commenced on 28 March 2008 at 10.00am.

The directors have resolved that the company will be able to pay its debts.

Pursuant to section 243(8) of the Companies Act 1993, a copy of the resolution has been delivered to the Registrar of Companies.

Notice to Creditors to Claim

Notice is hereby given that the undersigned, the liquidator of the above-named company which is being liquidated, does hereby fix 28 April 2008, as the day on or before which the creditors of the company are to make their claims and to establish any priority their claims may have, under section 312 of the Companies Act 1993, or to be excluded from the benefit of any distribution made before their claims are made or excluded from objecting to any distribution made before the priority of their claim is established.

Creditors and shareholders may direct enquiries to me during normal business hours at the address and contact numbers stated below.

BRUCE DONALD GEMMELL, Liquidator.

Liquidator's Address: KPMG at Cranmer, Fifth Floor, 34–36 Cranmer Square (PO Box 274), Christchurch. Telephone: (03) 363 5788. Facsimile: (09) 363 5765.

Officer for Enquiries: Alex Eason.

Note: This is a solvent liquidation being part of an organisation reconstruction.

al2165

Richter Investments Limited (in liquidation)

Notice of Appointment of Liquidators

Notice is hereby given that, pursuant to section 241(2)(a) of the Companies Act 1993, Roderick Neil Gillespie and James Anthony Young were appointed joint and several liquidators of Richter Investments Limited (in liquidation).

The liquidation commenced on 20 March 2008 at 9.00am.

Notice to Creditors to Claim

Notice is also given that the liquidators hereby fix Friday, 18 April 2008, as the day on or before which the creditors of the company are to make their claims and to establish any priority their claims may have under section 312 of the Companies Act 1993.

Enquiries may be directed by a creditor or shareholder of the company during normal business hours to R. N. Gillespie, Gillespie Young Watson, PO Box 30940, Lower Hutt, or telephone (04) 569 3997.

R. N. GILLESPIE, Liquidator.

al2132

Pedlars Recyclers Limited (in liquidation)

Notice of Appointment of Liquidators

Notice is hereby given that, pursuant to section 241(2)(a) of the Companies Act 1993, Edward Christian Jansen and Brian Joseph Walshe were appointed joint and several liquidators of Pedlars Recyclers Limited (in liquidation).

The liquidation commenced on 18 March 2008 at 9.00am.

Notice to Creditors to Claim

Notice is also given that the liquidators hereby fix 17 April 2008, as the day on or before which the creditors of the company are to make their claims and to establish any priority their claims may have under section 312 of the Companies Act 1993.

Enquiries may be directed by a creditor or shareholder of the company during normal business hours to Edward Jansen at PO Box 30568, Lower Hutt, or telephone (04) 569 9069.

EDWARD CHRISTIAN JANSEN, Liquidator, WHK Sherwin Chan & Walshe (a division of WHK (NZ) Limited).

al2183

Pursuit Property No1 Limited (in liquidation)

Notice of Appointment of Liquidator and Notice to Creditors to Prove Debts or Claims

Notice is hereby given that, in accordance with section 241 of the Companies Act 1993, the shareholders of the above-named company on 25 March 2008 at 11.06am, appointed Robert James Taylor, chartered accountant of Auckland, as liquidator of the above-named company.

The undersigned does hereby fix 1 May 2008, as the day on or before which the creditors of the company are to prove their debts or claims and to establish any title they may have to priority, under section 312 of the Companies Act 1993, or to be excluded from the benefit of any distribution made before the debts are proved or, as the case may be, from objecting to the distribution.

ROBERT JAMES TAYLOR, Liquidator.

Address of Liquidator: Christmas Gouwland Limited, PO Box 106090, Auckland. Telephone: (09) 309 1799. Facsimile: (09) 307 3113.

Enquiries to: Grant Sheffield. Direct Dial: (09) 302 6168.

al2119

Dahomey Limited (in liquidation)

Notice of Appointment of Liquidators

Pursuant to Section 3, 255(2)(a) of the Companies Act 1993

On 18 March 2008 at 8.45pm, it was resolved by special resolution of the shareholders, pursuant to section 241(2) of the Companies Act 1993, that Dahomey Limited be liquidated and that John Albert Price, insolvency practitioner, and Christopher Robert Ross Horton, chartered accountant, be appointed liquidators jointly and severally for that purpose.

A solvency certificate has been filed by the directors with the Registrar in accordance with section 243(9) of the Companies Act 1993.

Notice to Creditors to Prove Debts or Claims

Notice is given that the liquidators fix 30 April 2008, as the day on or before which the creditors of the company are to make their claims and to establish any priority their claims may have under section 312 of the Companies Act 1993.

JOHN PRICE, Liquidator.

Creditors May Direct Enquiries to the Liquidators at: Dahomey Limited (in liquidation), c/o Horton Price Limited, PO Box 9125, Newmarket, Auckland. Telephone: (09) 366 3700. Facsimile: (09) 366 7276.

al2158

November Properties 1995 Limited (in liquidation)

Notice of Appointment of Liquidator and Notice to Creditors to Prove Debts or Claims

Notice is hereby given that, subsequent to a resolution as to solvency and in accordance with section 241(2)(a) of the Companies Act 1993, the shareholders of the above-named company on 20 March 2008 at 11.40am, appointed Graeme George McDonald, chartered accountant of Auckland, liquidator of the company.

The undersigned does hereby fix 24 April 2008, as the day on or before which the creditors of the company are to prove their debts or claims and to establish any title they may have to priority, under section 312 of the Companies Act 1993, or to be excluded from the benefit of any distribution made before the debts are proved or, as the case may be, from objecting to the distribution.

GRAEME G. McDONALD, Liquidator.

Date of Liquidation: 20 March 2008.

Address of Liquidators: Apex Accounting Limited, Unit 3A, 517 Mt Wellington Highway (PO Box 7719), Wellesley Street Post Office, Auckland. Telephone: (09) 573 5840. Facsimile: (09) 573 5359.

Note: This is a solvent liquidation.

al2113

Hope Island Holdings Limited (in liquidation)

Notice of Appointment of Liquidator and Notice to Creditors to Claim

The shareholders of the company resolved, pursuant to section 241(2)(a) of the Companies Act 1993, that Gordon L. Hansen, chartered accountant of Christchurch, be appointed liquidator.

The liquidation commenced on 27 March 2008 at 4.00pm.

Creditors of the company are to file their claims with the liquidator and to establish any priority their claims may have on or before 20 working days from the date of this notice.

Creditors and shareholders may direct enquiries to the liquidator during normal business hours at the address and contact numbers stated below.

Dated this 28th day of March 2008.

G. L. HANSEN, Liquidator.

Address of Liquidator: Goldsmith Fox PKF, PO Box 13141, Christchurch. Telephone: (03) 366 6706. Facsimile: (03) 366 0265.

Note: The company is being liquidated as part of the restructuring of the business affairs of the shareholders. A certificate of solvency has been signed by the director of the company.

al2164

NZ Reit Limited (in liquidation)

Notice of Appointment of Liquidator

Notice is hereby given that, pursuant to section 241(2)(a) of the Companies Act 1993, Robin Winston Hargrave, chartered accountant of O'Halloran HMT Limited, was appointed liquidator of NZ Reit Limited.

The liquidation commenced on 26 March 2008 at 3.00pm.

Notice to Creditors to Claim

Notice is also given that the liquidator hereby fixes 26 April 2008, as the day on or before which the creditors of the company are to make their claims and to establish any priority their claims may have under section 312 of the Companies Act 1993.

Enquiries may be directed by a creditor or shareholder of the company during normal business hours to Robin Winston Hargrave at O'Halloran HMT Limited. Telephone: (09) 366 5065. Facsimile: (09) 366 5001.

ROBIN WINSTON HARGRAVE, Liquidator.

Address for Service: PO Box 6004, Wellesley Street, Auckland.

Note: This is a solvent liquidation and the liquidation is a result of the restructuring of the business affairs of the shareholders.

al2152

DJL Industries Limited (in liquidation)

Notice of Appointment of Liquidator and Notice to Creditors to Claim

On 25 March 2008 at 10.30am, it was resolved by special resolution of shareholders, pursuant to section 241(2)(a) of the Companies Act 1993, that DJL Industries Limited be placed into liquidation and that Gael Hotchin, chartered accountant of Auckland, be appointed liquidator.

The liquidation commenced on 25 March 2008 at 10.30am.

The liquidator hereby fixes 25 April 2008, as the day on or before which the creditors of the company are to make their claim and to establish any priority their claims may have, under section 312 of the Companies Act 1993, or to be excluded from the benefit of any distribution made before the claims are made or, as the case may be, from objecting to any distribution.

Dated this 25th day of March 2008.

GAEL HOTCHIN, Liquidator.

Address of Liquidator: Grange Associates Limited, PO Box 99967, Newmarket, Auckland. Telephone: (09) 623 3144. Facsimile: (09) 623 3145.

Note: The company is solvent and the liquidation is for administrative purposes only.

al2080

Te Uki Tamariki Ou Cook Island Incorporated (in liquidation)

Notice of Appointment of Liquidators

Pursuant to Section 255(2)(a) of the Companies Act 1993

Dennis Clifford Parsons and Katherine Louise Kenealy were appointed joint and several liquidators of Te Uki Tamariki Ou Cook Island Incorporated (in liquidation) on 27 March 2008 at 10.20am.

D. C. PARSONS, Liquidator.

Address for Service: Indepth Forensic Limited, PO Box 278, Hamilton. Telephone: (07) 957 8674. Website: www.indepth.co.nz

al2138

Alstom New Zealand Limited (in liquidation)

Notice of Appointment of Liquidator and Notice to Creditors to Claim

Notice is given that, by way of resolution of the shareholders of the above-named company in accordance with section 122 of the Companies Act 1993, Douglas Kim Fisher, chartered accountant of Auckland, was appointed liquidator of the company on 28 March 2008.

The liquidation commenced on 28 March 2008 at 2.00pm.

The liquidator does hereby fix Thursday, 24 April 2008, as the day on or before which the creditors of the company are to make their claims and to establish any priority their claims may have, under section 312 of the Companies Act 1993, or to be excluded from the benefit of any distribution made before their claims are made or, as the case may be, from objecting to any distribution.

D. K. FISHER, Liquidator.

Address of Liquidator: Douglas Kim Fisher, Private Bag MBE M215, Auckland. Telephone: (09) 630 0491. Facsimile: (09) 638 6283.

al2181

Madison House Limited and Madison Lifestyle Village Limited (both in liquidation)

Notice of Appointment of Liquidator

On 25 March 2008 at 9.00am, Raymond Gordon Burgess was appointed liquidator of the above-named companies.

Notice to Creditors to Prove Debts or Claims

Notice is given that the liquidator fixes 28 April 2008, as the day on or before which the creditors of the above-named companies are to make their claims and to establish any priority their claims may have, under section 312 of the Companies Act 1993, or to be excluded from the benefit of any distribution made before their claims are made or, as the case may be, from objecting to the distribution.

RAYMOND G. BURGESS, Liquidator.

Address for Service: PO Box 82100, Auckland. Telephone: (09) 576 7806. Facsimile: (09) 576 7263.

Note: A notice of solvency resolution has been filed for each company.

al2106

London Traders Limited (in liquidation)

Public Notice of Appointment of Liquidator and Notice to Creditors to Claim

Pursuant to Section 255(2)(a) of the Companies Act 1993

On 18 March 2008, it was resolved by special resolution, pursuant to section 241(2)(a) of the Companies Act 1993, that London Traders Limited be liquidated and that Roderick Thomas McKenzie, of McKenzie & Partners

Limited, Chartered Accountants, Palmerston North, be appointed liquidator.

The liquidation commenced on 18 March 2008 at 10.30am.

The liquidator has fixed Friday, 24 April 2008, as the last day for creditors to make their claims and to establish any priority their claims may have under section 312 of the Companies Act 1993.

Creditors who have not made a claim at the date a distribution is declared will be excluded from the benefit of that distribution and may not object to that distribution.

Any enquiries may be directed to the liquidator during normal business hours at the address and contact numbers stated below.

RODERICK THOMAS MCKENZIE, Liquidator.

Address for Service: McKenzie & Partners Limited, Level 1, 484 Main Street (PO Box 12014), Palmerston North. Telephone: (06) 354 9639. Facsimile: (06) 356 2028.

al2060

Waimarie Homecare Limited and Waimarie Aged Care Limited (both in liquidation)

Notice of Appointment of Liquidators and Notice to Creditors to Prove Debts or Claims

Notice is hereby given that, subsequent to a resolution as to solvency and in accordance with section 241(2)(a) of the Companies Act 1993, the shareholders of the above-named company on 19 March 2008 at 5.00pm, appointed Victoria Toon and Boris van Delden, chartered accountants of Auckland, jointly and severally as liquidators of the above-named companies.

The undersigned does hereby fix 2 May 2008, as the day on or before which the creditors of the companies are to prove their debts or claims and to establish any title they may have to priority, under section 312 of the Companies Act 1993, or to be excluded from the benefit of any distribution made before the debts are proved or, as the case may be, from objecting to the distribution.

VICTORIA TOON, Liquidator.

Date of Liquidation: 19 March 2008.

Address of Liquidators: McDonald Vague, Chartered Accountants, PO Box 6092, Wellesley Street Post Office, Auckland. Telephone: (09) 303 0506. Facsimile: (09) 303 0508.

Enquiries to: Victoria Toon.

Note: These are solvent liquidations and the liquidations are a result of the restructuring of the business affairs of the shareholders.

al2083

H4 Construction Limited (in liquidation)

Notice of Appointment of Liquidators and Notice to Creditors to Prove Debts or Claims

Notice is hereby given that, in accordance with section 255(2) of the Companies Act 1993, the High Court at Wellington on 17 March 2008 at 10.00am, appointed John Trevor Whittfield and Boris van Delden, insolvency practitioners of Auckland, jointly and severally as liquidators of the above-named company.

The undersigned does hereby fix Friday, 25 April 2008, as the day on or before which the creditors of the company are to prove their debts or claims and to establish any title they may have to priority, under section 312 of the Companies Act 1993, or to be excluded from the benefit of any distribution made before the debts are proved or, as the case may be, from objecting to the distribution.

JOHN T. WHITTFIELD, Liquidator.

Date of Liquidation: 17 March 2008.

Address of Liquidators: McDonald Vague, PO Box 6092, Wellesley Street Post Office, Auckland. Telephone: (09) 303 0506. Facsimile: (09) 303 0508. Website: www.mvp.co.nz

Enquiries to: Kevin Bromwich. Telephone: (09) 303 9514.

al2059

The Jolly Engineer Limited (in liquidation)

Notice of Appointment of Liquidators and Notice to Creditors to Prove Debts or Claims

Notice is hereby given that, in accordance with section 241 of the Companies Act 1993, the shareholders of the above-named company on 19 March 2008 at 8.45am, appointed John Trevor Whittfield and Boris van Delden, insolvency practitioners of Auckland, jointly and severally as liquidators of the above-named company.

The undersigned does hereby fix 20 April 2008, as the day on or before which the creditors of the company are to prove their debts or claims and to establish any title they may have to priority, under section 312 of the Companies Act 1993, or to be excluded from the benefit of any distribution made before the debts are proved or, as the case may be, from objecting to the distribution.

JOHN T. WHITTFIELD, Liquidator.

Date of Liquidation: 19 March 2008.

Address of Liquidators: McDonald Vague, PO Box 6092, Wellesley Street Post Office, Auckland. Telephone: (09) 303 0506. Facsimile: (09) 303 0508. Website: www.mvp.co.nz

Enquiries to: Kevin Bromwich. Telephone: (09) 303 9514.

al2078

W.Scott/Morris Auto Electrical Limited (in liquidation)

Notice of Appointment of Liquidators and Notice to Creditors to Prove Debts or Claims

Notice is hereby given that, in accordance with section 241 of the Companies Act 1993, the shareholders of the above-named company on 25 March 2008 at 11.45am, appointed John Trevor Whittfield and Boris van Delden, insolvency practitioners of Auckland, jointly and severally as liquidators of the above-named company.

The undersigned does hereby fix 9 May 2008, as the day on or before which the creditors of the company are to prove their debts or claims and to establish any title they may have to priority, under section 312 of the Companies Act 1993, or to be excluded from the benefit of any distribution made before the debts are proved or, as the case may be, from objecting to the distribution.

JOHN T. WHITTFIELD, Liquidator.

Date of Liquidation: 25 March 2008.

Address of Liquidators: McDonald Vague, PO Box 6092, Wellesley Street Post Office, Auckland. Telephone: (09) 303 0506. Facsimile: (09) 303 0508. Website: www.mvp.co.nz

Enquiries to: Jonathan Barrett. Telephone: (09) 306 3357.

al2099

Lorraine Adams Design Limited (in liquidation)

Notice of Appointment of Liquidators

Take notice that Lorraine Adams Design Limited (in liquidation) was ordered by the High Court at Christchurch, pursuant to section 241(2)(c) of the Companies Act 1993, on 3 March 2008 to be put into liquidation.

Paul William Gerrard Jenkins and Wayne John Deuchrass were appointed liquidators jointly and severally.
The liquidation commenced on 3 March 2008 at 10.26am.
Creditors may make enquiries to the liquidators, whose address is c/o Insolvency Management Limited, Level 1, 148 Victoria Street (PO Box 13401), Christchurch.

al2175

Suite Centre Limited (in liquidation)

Notice of Appointment of Liquidators

Take notice that Suite Centre Limited (in liquidation) was ordered by the High Court at Christchurch, pursuant to section 241(2)(c) of the Companies Act 1993, on 3 March 2008 to be put into liquidation.

Paul William Gerrard Jenkins and Wayne John Deuchrass were appointed liquidators jointly and severally.

The liquidation commenced on 3 March 2008 at 10.28am.

Creditors may make enquiries to the liquidators, whose address is c/o Insolvency Management Limited, Level 1, 148 Victoria Street (PO Box 13401), Christchurch.

al2176

Balmoral Homes Limited (in liquidation)

Notice of Appointment of Interim Liquidators

Take notice that Balmoral Homes Limited (in liquidation) was ordered by the High Court at Christchurch, pursuant to section 246(1) of the Companies Act 1993, on 18 March 2008 at 8.30am to be put into interim liquidation.

Iain Andrew Nellies and Wayne John Deuchrass were appointed interim liquidators jointly and severally.

The application to appoint a liquidator by Bathroom Solutions Limited will be heard at the High Court at Christchurch on 14 April 2008 at 9.30am.

Further particulars regarding this application can be obtained from the Court or the applicant's solicitor, Hamish Evans, of Young Hunter, Barristers & Solicitors, Christchurch.

Creditors may make enquiries to the interim liquidators whose address is c/o Insolvency Management Limited, Level 1, 148 Victoria Street (PO Box 13401), Christchurch.

al2177

SJG Construction Limited (in liquidation)

Notice of Appointment of Liquidators

Take notice that SJG Construction Limited (in liquidation) was ordered by the High Court at Dunedin, pursuant to section 241(2)(c) of the Companies Act 1993, on 27 March 2008 to be put into liquidation.

Iain Andrew Nellies and Paul William Gerrard Jenkins were appointed liquidators jointly and severally.

The liquidation commenced on 27 March 2008 at 10.08am.

Creditors may make enquiries to the liquidators, whose address is c/o Insolvency Management Limited, Level 3, Burns House, 10 George Street (PO Box 1058), Dunedin.

al2178

Wanaka Gas Limited (in liquidation)

Notice of Appointment of Liquidators

Take notice that Wanaka Gas Limited (in liquidation) was ordered by the High Court at Dunedin, pursuant to section 241(2)(c) of the Companies Act 1993, on 27 March 2008 to be put into liquidation.

Iain Andrew Nellies and Paul William Gerrard Jenkins were appointed liquidators jointly and severally.

The liquidation commenced on 27 March 2008 at 10.17am.
Creditors may make enquiries to the liquidators, whose address is c/o Insolvency Management Limited, Level 3, Burns House, 10 George Street (PO Box 1058), Dunedin.

al2179

PJM Properties Limited (in liquidation)

Notice of Appointment of Liquidators

Take notice that PJM Properties Limited (in liquidation) resolved, pursuant to section 241(2)(a) of the Companies Act 1993, on 28 March 2008 to be put into liquidation.

Iain Andrew Nellies and Wayne John Deuchrass were appointed liquidators jointly and severally.

The liquidation commenced on 28 March 2008 at 3.15pm.

Creditors may make enquiries to the liquidators, whose address is c/o Insolvency Management Limited, Level 3, Burns House, 10 George Street (PO Box 1058), Dunedin.

al2180

Broadbeach Group Limited

Notice of Appointment of Liquidator and Notice to Creditors to Claim

Pursuant to Section 255(2) of the Companies Act 1993

In the matter of section 241(2)(c) of the Companies Act 1993, and in the matter of **Broadbeach Group Limited**:

Notice is hereby given that the company was placed into liquidation on 26 March 2008 at 10.38am, with the appointment of Grant Bruce Reynolds as liquidator for the company.

The liquidator fixes 30 April 2008, as the day on or before which the creditors of the company are to prove their debts or claims and to establish any title they may have to priority, under section 312 of the Companies Act 1993, or to be excluded from the benefit of any distribution made before the debts are proved or, as the case may be, from objecting to the distribution.

Dated at Auckland this 27th day of March 2008.

GRANT BRUCE REYNOLDS.

Address for Service: Reynolds & Associates Limited, PO Box 259059, Greenmount, Auckland. Telephone: (09) 526 0743. Facsimile: (09) 526 0748.

al2112

Macron Holdings Limited (in liquidation)

Notice of Appointment of Liquidator

Pursuant to Section 3, 255(2)(a) of the Companies Act 1993

On 1 March 2008, it was resolved, pursuant to section 241(2)(a) of the Companies Act 1993, that Macron Holdings Limited be liquidated and that John Patrick Chapman, of Wellsford, director of Bavage Chapman Limited, Chartered Accountants, Wellsford, be appointed liquidator for this purpose.

The liquidation commenced on 20 March 2008.

Creditors and shareholders may direct enquiries to me during normal business hours at the address and telephone number stated below.

Dated this 20th day of March 2008.

JOHN PATRICK CHAPMAN.

Address of Liquidator: Bavage Chapman Limited, Chartered Accountants, 142 Rodney Street, Wellsford. Telephone: (09) 423 8143 (extension 210). Facsimile: (09) 423 7226. Email: john@bavagechapman.co.nz

al2061

MEETINGS AND LAST DATES BY WHICH TO PROVE DEBTS OR CLAIMS

Ambition Wholesalers Limited (formerly **ASOTV Wholesalers Limited***) (in liquidation)

Pursuant to Section 243(3) of the Companies Act 1993

Notice of Meeting of Creditors

Notice is hereby given that a first meeting of creditors of Ambition Wholesalers Limited (in liquidation) is to be held on 4 April 2008 at 10.00am at the offices of the liquidators, Level 3, 48 Courthouse Lane, Chancery Building, Auckland.

Forms of general and special proxies are available from the office of the liquidators at the address below.

Proxies to be used at the meeting must be lodged at the office of the liquidators no later than 2 April 2008 at 10.00am.

Creditors and members may direct enquiries to the liquidators during normal business hours.

STEPHEN M. LAWRENCE, Liquidator.

Address for Service: Horwath Corporate (Auckland) Limited, PO Box 3678, Shortland Street, Auckland 1140. Telephone: (09) 302 0521. Facsimile: (09) 302 0536.

Attention: Shelley Palman.

*This company was trading as Adman until July 2007.

md2139

Eventmakers International Limited (in liquidation)

Notice of Creditors' Meeting

Notice is hereby given that, pursuant to section 243 of the Companies Act 1993, the liquidators will be holding a creditors' meeting on Monday, 7 April 2008 at 10.00am at the offices of Waterstone Insolvency, Unit K1, 75 Corinthian Drive, Albany, Auckland.

Agenda

1. Confirmation of appointment.
2. Liquidators' initial report.

3. Liquidation committee.

4. General business.

If you have not yet filed a proof of debt, please do so by sending us a completed creditors' claim form which is available on our website.

Dated this 25th day of March 2008.

DAMIEN GRANT and STEVEN KHOV, Joint Liquidators.

Address for Liquidators: Waterstone Insolvency, PO Box 352, Auckland. Telephone: 0800 CLOSED. Facsimile: 0800 FAXWSI.

md2088

Swordfish Lodge Management Limited (trading as **Gulf Harbour Lodge**) (administrators appointed)

Notice of Reconvened Watershed Meeting of Creditors

Pursuant to Section 239AU of the Companies Act 1993

Bernard Spencer Montgomerie and Stuart James Cunningham, insolvency practitioners of Auckland, were appointed administrators of Swordfish Lodge Management Limited (administrators appointed) on 4 March 2008 at 1.15pm.

Take notice that the reconvened watershed meeting of creditors will take place at The Auckland Club, 34 Shortland Street, Auckland, on Wednesday, 9 April 2008 at 11.00am.

Registration will commence at 10.45am.

Creditors and shareholders of the company may direct enquiries during normal business hours to Montgomerie & Associates, PO Box 65, Auckland 1140. Telephone: (09) 368 7672. Facsimile: (09) 307 0174. Email: bsm@montgomerie.co.nz

BERNARD S. MONTGOMERIE, Administrator.

Note: Proxies and voting papers are to be received by the administrators by 10.00am on Tuesday, 8 April 2008.

md2159

REMOVALS

Notice of Intention to Remove Companies From the Register

I intend to remove the following companies from the Register under section 318(1)(d) of the Companies Act 1993.

I am satisfied that these companies have ceased to carry on business and there is no other reason for these companies to continue in existence or that no liquidator is acting.

201 GRACEFIELD ROAD LIMITED.

A & H (2006) LIMITED.

ALMAC INVESTMENTS LIMITED.

ANDBEV LIMITED.

ASCOT PROPERTIES (BIRCH ST) LIMITED.

ASHTON OF MARLBOROUGH LIMITED.

BELLEVUE OSTEOPATHIC PRACTICE LIMITED.

BLACK DOG INDUSTRIES LIMITED.

BOSKOVIC & COBB FISHERIES LIMITED.

BOWEN MANAGEMENT NO. 14 LIMITED.

BRYSNIC HOLDINGS LIMITED.

CAMERON PROPERTIES LIMITED.

CARPARK LIMITED.

CELLARS OF HAWKES BAY LIMITED.

CELLARS OF MARLBOROUGH (2004) LIMITED.

CHISEL COMMUNICATIONS LIMITED.

CORUBA JAMAICA RUM LIMITED.

DIVERSIFIED MARKETING SERVICES LIMITED.

DOWNTOWN ESTATE LIMITED.

ECO POWER SYSTEMS LIMITED.

EMPIRE DEVELOPMENTS LIMITED.

FIORDLAND ESTATES LIMITED.

FLAXMERE COMPOUNDING LIMITED.

FLUTEY INVESTMENTS LIMITED.

FOPOU INTERNATIONAL LIMITED.

FUTURE PROTECTION AND FINANCE LIMITED.

GLENDARUEL HOLDINGS LIMITED.

GLENTOI LIMITED.

GREG BIGGS KITCHENS & JOINERY LIMITED.

GROUND CARE LIMITED.

HAVEN NATURAL THERAPIES LIMITED.

HEARTLAND FIFTEEN INVESTMENTS LIMITED.

J A & F J BROOKING LIMITED.

KELLAHAN NEW ZEALAND LIMITED.

L D & D H CURRIE LIMITED.

LOOKING GOOD LIMITED.

MODENA PROPERTY ONE LIMITED.

MOONSHINE HOLDINGS LIMITED.

NICK GRANT & ASSOCIATES LIMITED.

P & S LUCAS LIMITED.
 PATRICK WILSON DESIGN LIMITED.
 PAVILION ADVERTISING LIMITED.
 RCPC LIMITED.
 RCPH LIMITED.
 RCPS LIMITED.
 RUCKING LIMITED.
 S CARTER PROPERTIES LIMITED.
 SOUTH POLE LIMITED.
 TAIERI PEAK LIMITED.
 TELETALK AUCKLAND LIMITED.
 THE ESTIMATOR NELSON LIMITED.
 TWIN PROPERTY INVESTMENTS LIMITED.
 URBAN NOMAD TRADING LIMITED.
 VERY FINANCE LIMITED.
 VIGERS INTERNATIONAL PROPERTY ADVISERS
 NZ PTY LIMITED.
 VIRGO PROPERTIES LIMITED.
 WAIHEKE CONFERENCE PLANNERS LIMITED.
 WAIRARAPA GEMTIME JEWELLER HOLDINGS
 LIMITED.
 WAIRONGOA DOWNS LIMITED.
 WHITE ROSE PROPERTIES LIMITED.

Unless, under section 321 of the Companies Act 1993, written objection to removal of any of the above-named companies is delivered to the Registrar by 2 May 2008 (being not less than 20 working days from the date of this notice), the Registrar is required to remove the companies from the Register.

Dated this 3rd day of April 2008.

NEVILLE HARRIS, Registrar of Companies.

Contact for Enquiries: 0508 COMPANIES (0508 266 726).

Postal Address for Written Objections: The Registrar of Companies, Northern Business Centre, Private Bag 92061, Auckland Mail Centre.

Facsimile No. for Written Objections: (09) 916 4559.

ds2258

Alpine Properties Limited, Aspil Limited, B52 Holdings Limited, Beaver Shack Limited, Berakas Corporation Limited, Blockbusters Limited, Bristol Investments Limited and Broken Yellow Line Limited (all in liquidation)

Notice of Application for Removal of the Above-named Companies From the Register

Pursuant to Section 257(1)(b) of the Companies Act 1993

Notice is given that it is intended to remove from the New Zealand Register the above-named companies on the grounds that the liquidations have been completed and the liquidator's final reports have been filed with the Registrar.

Any objection to the removals, under section 257(1)(b), must be lodged with the Registrar within 28 days of the date of this notice.

Dated this 17th day of March 2008.

J. M. GILBERT, Liquidator.

ds2098

Strand Fisk & Muldoon Limited (in liquidation)

Public Notice of Intention to Remove Company From the Register

Notice is given of the intention to remove Strand Fisk & Muldoon Limited (in liquidation) from the Register

of Companies, in accordance with section 318(1)(e) of the Companies Act 1993, on the grounds of the delivery of the final liquidation documents to the Registrar in accordance with section 257(1)(a).

Any objection to the intended removal must be delivered to the Registrar of Companies no later than 28 days from the date of this notice.

EDWARD CHRISTIAN JANSEN, Liquidator, WHK Sherwin Chan & Walshe (a division of WHK (NZ) Limited).

ds2184

Hollie Developments Limited and Midas Developments Solution Dynamics Limited (both in liquidation)

Notice of Intention to Remove Companies From the Register

In the matter of the Companies Act 1993, and in the matter of **Hollie Developments Limited** and **Midas Developments Solution Dynamics Limited** (both in liquidation):

Notice is hereby given, in pursuance of section 318 of the Companies Act 1993 ("the Act"), that:

- (a) It is intended that the above-named companies be removed from the Register, under section 318(1)(e) of the Act, on the grounds that the duties of the liquidator have been completed and the liquidator has sent to the Registrar the documents referred to in section 257(1)(a) of the Act.
- (b) Any objection to the removals, under section 321 of the Act, must be lodged with the Registrar together with the grounds for such objection no later than 25 April 2008.

Dated at Auckland this 18th day of March 2008.

PERI FINNIGAN, Liquidator.

Address of Liquidator and Address for Service of Company: McDonald Vague, Chartered Accountants, 80 Greys Avenue, Auckland. *Postal Address:* PO Box 6092, Wellesley Street, Auckland.

ds2045

Perimac New Zealand Limited (in liquidation)

Notice of Intention to Remove Company From the Register

In the matter of the Companies Act 1993, and in the matter of **Perimac New Zealand Limited** (in liquidation):

Notice is hereby given, in pursuance of section 320 of the Companies Act 1993 ("the Act"), that:

- (a) It is intended that the above-named company be removed from the Register, under section 318(1)(e) of the Act, on the grounds that the duties of the liquidator have been completed and the liquidator has sent to the Registrar the documents referred to in section 257(1)(a) of the Act.
- (b) Any objection to the removal, under section 321 of the Act, must be lodged with the Registrar together with the grounds for such objection no later than 28 April 2008.

Dated at Auckland this 26th day of March 2008.

BORIS VAN DELDEN, Liquidator.

Address of Liquidator and Address for Service of Company: McDonald Vague, Insolvency Specialists, 80 Greys Avenue, Auckland. *Postal Address:* PO Box 6092, Wellesley Street, Auckland. Website: www.mvp.co.nz

ds2128



Albert Navaho Limited (in liquidation)**Notice of Intention to Request Removal of the Above-named Company From the Register**

Pursuant to Section 321 of the Companies Act 1993

Company No.: 1012381

I, Jurgen W. Herbke, hereby give notice that I have applied to the Registrar of Companies at Auckland for the removal of the above-named company, having its registered office at Porto Road, Dargaville, on the grounds that the company has ceased to carry on business and has discharged in full its liabilities to all known creditors.

Unless written objection is made to the Registrar of Companies by 25 April 2008, the company will be removed from the Register.

Dated this 21st day of March 2008.

JURGEN W. HERBKE, Liquidator.

ds2041

P L Macpherson Holdings Limited (in liquidation)**Notice of Intention to Remove Company From the Register**

Pursuant to Section 320 of the Companies Act 1993

I, John David Naylor, liquidator of P L Macpherson Holdings Limited, hereby give notice that, pursuant to section 318(1)(e) of the Companies Act 1993 and having filed with the Registrar my final report on the liquidation, it is intended to remove the company from the New Zealand Register.

Any objection to the removal, pursuant to section 321 of the Companies Act 1993, must be delivered to the Registrar no later than 29 April 2008.

Dated this 31st day of March 2008.

J. D. NAYLOR, Liquidator, P L Macpherson Holdings Limited (in liquidation).

ds2174

Petrosian Enterprises Limited (in liquidation)**Notice of Intended Removal of the Above-named Company From the Register**

Notice is hereby given that I, the undersigned liquidator of Petrosian Enterprises Limited (in liquidation), whose registered office is situated at 136-138 Powderham Street, New Plymouth, intend to deliver to the Registrar of Companies the final reports and statements referred to in section 257(1)(a) of the Companies Act 1993 with the intent that the company be removed from the New Zealand Register, pursuant to section 318(1)(e) of the Companies Act 1993, on the grounds that the liquidation of the company has been completed.

Unless written objection to such removal, under section 321 of the Act, is delivered to the Registrar of Companies at Auckland by 9 May 2008 (being a date not less than 20 working days after the date of this notice), the Registrar may remove the company from the Register.

Dated this 27th day of March 2008.

CHRISTOPHER JOHN LYNCH, Liquidator.

ds2125

Coffs - Kocass Pty Ltd**Notice of Intention to Apply for Removal of the Above-named Company From the Overseas Register**

Notice is hereby given that I, the undersigned applicant, propose to apply to the Registrar of Companies, pursuant to section 341(1) of the Companies Act 1993, for the removal

of Coffs - Kocass Pty Ltd from the New Zealand Overseas Register on the grounds that this company ceased to carry on business in New Zealand in 2007.

Unless written objection to such removal, pursuant to section 341(1) of the Act, is sent or delivered to the Registrar at Auckland by 27 June 2008 (being a date not less than three months from the date of this notice), the Registrar may remove the company from the Register.

WILLIAM KOCASS, Director.

ds2123

BBMFL Investments Limited (in liquidation)**Public Notice of Intention to Apply for Removal of the Above-named Company From the Register**

Public notice is given that, pursuant to section 318(1)(e) of the Companies Act 1993, the Registrar of Companies must remove BBMFL Investments Limited (in liquidation), whose registered office is situated at Level 5, 50 Anzac Avenue, Auckland, from the New Zealand Register on the grounds that the documents referred to in section 257(1)(a) of the Companies Act 1993 have been sent or delivered to the Registrar of Companies, thereby completing the liquidation pursuant to section 249 of the Act.

Unless, pursuant to section 321 of the Act, written objection to the removal is delivered to the Registrar by 17 April 2008, the Registrar is obliged to remove the company from the Register.

Dated at Auckland this 26th day of March 2008.

JUGDIS HIRA PARBHU, Liquidator.

Address for Service: 2B William Pickering Drive, North Harbour, Auckland. Telephone: (09) 414 1200. Facsimile: (09) 414 1920.

ds2093

TRAL Investments Limited (in liquidation)**Public Notice of Intention to Apply for Removal of the Above-named Company From the Register**

Public notice is given that, pursuant to section 318(1)(e) of the Companies Act 1993, the Registrar of Companies must remove TRAL Investments Limited (in liquidation), whose registered office is situated at Level 5, 50 Anzac Avenue, Auckland, from the New Zealand Register on the grounds that the documents referred to in section 257(1)(a) of the Companies Act 1993 have been sent or delivered to the Registrar of Companies, thereby completing the liquidation pursuant to section 249 of the Act.

Unless, pursuant to section 321 of the Act, written objection to the removal is delivered to the Registrar by 17 April 2008, the Registrar is obliged to remove the company from the Register.

Dated at Auckland this 26th day of March 2008.

JUGDIS HIRA PARBHU, Liquidator.

Address for Service: 2B William Pickering Drive, North Harbour, Auckland. Telephone: (09) 414 1200. Facsimile: (09) 414 1920.

ds2092

TRCL Holdings Limited (in liquidation)**Public Notice of Intention to Apply for Removal of the Above-named Company From the Register**

Public notice is given that, pursuant to section 318(1)(e) of the Companies Act 1993, the Registrar of Companies must remove TRCL Holdings Limited (in liquidation), whose registered office is situated at Level 5, 50 Anzac Avenue, Auckland, from the New Zealand Register on the grounds that the documents referred to in section 257(1)(a) of

the Companies Act 1993 have been sent or delivered to the Registrar of Companies, thereby completing the liquidation pursuant to section 249 of the Act.

Unless, pursuant to section 321 of the Act, written objection to the removal is delivered to the Registrar by 17 April 2008, the Registrar is obliged to remove the company from the Register.

Dated at Auckland this 26th day of March 2008.

JUGDIS HIRA PARBHU, Liquidator.

Address for Service: 2B William Pickering Drive, North Harbour, Auckland. Telephone: (09) 414 1200. Facsimile: (09) 414 1920.

ds2094

Trans-pac Express Limited (in liquidation)

Public Notice of Intention to Apply for Removal of the Above-named Company From the Register

Public notice is given that, pursuant to section 318(1)(e) of the Companies Act 1993, the Registrar of Companies must remove Trans-pac Express Limited (in liquidation), whose registered office is situated at Level 5, 50 Anzac Avenue, Auckland, from the New Zealand Register on the grounds that the documents referred to in section 257(1)(a) of the Companies Act 1993 have been sent or delivered to the Registrar of Companies, thereby completing the liquidation pursuant to section 249 of the Act.

Unless, pursuant to section 321 of the Act, written objection to the removal is delivered to the Registrar by 28 April 2008, the Registrar is obliged to remove the company from the Register.

Dated at Auckland this 3rd day of April 2008.

JUGDIS HIRA PARBHU, Liquidator.

Address for Service: 2B William Pickering Drive, North Harbour, Auckland. Telephone: (09) 414 1200. Facsimile: (09) 414 1920.

ds2189

Bush Road Properties Limited (in liquidation)

Notice of Intention to Remove the Above-named Company From the Register

Pursuant to Section 320 of the Companies Act 1993

We, Christopher Robert Ross Horton and John Albert Price, liquidators of Bush Road Properties Limited (in liquidation), hereby give notice that, pursuant to section 318(1)(e) of the Companies Act 1993 and having filed with the Registrar our final report on the liquidation, it is intended to remove the company from the New Zealand Register.

Any objection to the removal, pursuant to section 321 of the Companies Act 1993, must be delivered to the Registrar of Companies no later than 30 April 2008.

Dated this 28th day of March 2008.

C. R. R. HORTON, Joint Liquidator.

Address of Liquidator: C/o Horton Price Limited, 64 Khyber Pass Road, Auckland 1023. *Postal Address:* PO Box 9125, Newmarket, Auckland 1149.

ds2145

GA Group Services Limited (in liquidation) ("the company")

Notice of Intention to Remove Company From the Register

Pursuant to Section 320 of the Companies Act 1993

We, Richard Dale Agnew and John Anthony Waller, liquidators of the company, hereby give notice that, pursuant to section 318(1)(e) of the Companies Act 1993 ("the Act")

and having filed with the Registrar our final report on the liquidation, it is intended to remove the company from the New Zealand Register.

Any objection to the removal, pursuant to section 321 of the Act, must be delivered to the Registrar no later than 7 May 2008.

Dated this 27th day of March 2008.

RICHARD DALE AGNEW, Liquidator.

ds2129

Equity Management Holdings Limited (in liquidation)

Notice of Intention to Remove Company From the Register

Pursuant to Section 320 of the Companies Act 1993

We, Karen Betty Mason and Jeffrey Philip Meltzer, liquidators of Equity Management Holdings Limited (in liquidation), whose registered office is situated at Level 16, 7 City Road, Auckland, hereby give notice that, pursuant to section 318(1)(e) of the Companies Act 1993 and having filed with the Registrar our final report on the liquidation, it is intended to remove the company from the New Zealand Register.

Any objection to the removal, pursuant to section 321 of the Companies Act 1993, must be delivered to the Registrar of Companies no later than 12 May 2008.

Dated this 20th day of March 2008.

K. B. MASON, Liquidator.

Address of Liquidators: Meltzer Mason Heath, Level 16, 7 City Road, Auckland 1010. *Postal Address:* PO Box 6302, Wellesley Street, Auckland 1141.

ds2055

Quatro Construction Limited (in liquidation)

Notice of Intention to Remove Company From the Register

Pursuant to Section 320 of the Companies Act 1993

We, Karen Betty Mason and Jeffrey Philip Meltzer, liquidators of Quatro Construction Limited (in liquidation), whose registered office is situated at Level 16, 7 City Road, Auckland, hereby give notice that, pursuant to section 318(1)(e) of the Companies Act 1993 and having filed with the Registrar our final report on the liquidation, it is intended to remove the company from the New Zealand Register.

Any objection to the removal, pursuant to section 321 of the Companies Act 1993, must be delivered to the Registrar of Companies no later than 5 May 2008.

Dated this 20th day of March 2008.

K. B. MASON, Liquidator.

Address of Liquidators: Meltzer Mason Heath, Level 16, 7 City Road, Auckland 1010. *Postal Address:* PO Box 6302, Wellesley Street, Auckland 1141.

ds2056

Prado Construction Limited (formerly Landmarx Development (NZ) Limited) (in liquidation)

Notice of Intention to Remove Company From the Register

Pursuant to Section 320 of the Companies Act 1993

We, Karen Betty Mason and Jeffrey Philip Meltzer, liquidators of Prado Construction Limited (in liquidation), whose registered office is situated at Level 16, 7 City Road, Auckland, hereby give notice that, pursuant to section

318(1)(e) of the Companies Act 1993 and having filed with the Registrar our final report on the liquidation, it is intended to remove the company from the New Zealand Register.

Any objection to the removal, pursuant to section 321 of the Companies Act 1993, must be delivered to the Registrar of Companies no later than 9 May 2008.

Dated this 28th day of March 2008.

K. B. MASON, Liquidator.

Address of Liquidators: Meltzer Mason Heath, Level 16, 7 City Road, Auckland 1010. *Postal Address:* PO Box 6302, Wellesley Street, Auckland 1141.

ds2155

Cartledge Wool Exports Limited (in liquidation)

Notice of Intention to Apply for Removal of the Above-named Company From the Register

Pursuant to Section 320(2) of the Companies Act 1993

Address of Registered Office: Kendons Scott Macdonald Limited, Chartered Accountants, 119 Blenheim Road (PO Box 8621), Christchurch.

Notice is hereby given that, pursuant to section 318(1)(e) of the Companies Act 1993, the Registrar will be removing the above-named company from the Register on the grounds that the liquidator has completed his duties.

The liquidator has delivered the documents referred to in section 257(1)(a) of the Companies Act 1993 to the Registrar of Companies, thereby completing the liquidation pursuant to section 249 of the Act.

Any objection to removal, under section 321 of the Companies Act 1993, must be delivered to the Registrar by the 20th working day after the date of publication of this notice.

MICHAEL GERARD SCHIMANSKI, Liquidator.

ds2075

Hang Eleven Limited (in liquidation)

Notice of Intention to Apply for Removal of Company From the Register

Pursuant to Section 320(2) of the Companies Act 1993

We, Timothy Wilson Downes and Stephanie Beth Jeffreys, joint liquidators of Hang Eleven Limited (in liquidation), whose registered office is situated at Grant Thornton House, Level 4, 152 Fanshawe Street, Auckland, hereby give notice that, pursuant to section 318(1)(e) of the Companies Act 1993 and having filed with the Registrar of Companies our final report on the liquidation in terms of section 257 of the Act, it is intended to remove the company from the New Zealand Register.

Any objection to the removal, pursuant to section 321 of the Companies Act 1993, must be delivered to the Registrar of Companies no later than 20 April 2008.

Dated this 20th day of March 2008.

T. W. DOWNES, Liquidator.

Address of Liquidator: Grant Thornton Auckland Limited, 152 Fanshawe Street (PO Box 1961), Auckland.

ds2058

Somerset Services Limited (“the company”)

Notice of Intention to Apply for Removal of Company From the Register

Pursuant to Section 320(2) of the Companies Act 1993

Notice is hereby given by the undersigned applicant, being the shareholder of the company, that he proposes to make

application to the Registrar of Companies, pursuant to section 318(1)(d)(i) of the Companies Act 1993, for the removal of Somerset Services Limited, whose registered office is situated at 369 Devon Street East, New Plymouth, from the New Zealand Register on the grounds that the company has ceased to carry on business, has discharged in full its liabilities to all its known creditors, and has distributed its surplus assets in accordance with its constitution and the Companies Act 1993.

Notice is given that unless written objection to the removal of the company is sent or delivered to the Registrar, pursuant to section 321 of the Act, by 30 April 2008 (being a date not less than 20 working days after the date of this notice), the Registrar may remove the company from the Register.

Dated at New Plymouth this 27th day of March 2008.

WALTER STEWARD, Applicant and Shareholder.

ds2120

Glenshera Limited (in liquidation)

Public Notice of Intention to Apply for Removal of the Above-named Company From the Register

In the matter of the Companies Act 1993, and in the matter of **Glenshera Limited** (in liquidation):

Public notice is given that, pursuant to section 318(1)(e) of the Companies Act 1993, the Registrar of Companies must remove Glenshera Limited (in liquidation), whose registered office is situated at the offices of Smith Chilcott Bertelsen Harry, Chartered Accountants, Level 11, Shortland Tower One, 51–53 Shortland Street, Auckland, from the New Zealand Register on the grounds that the documents referred to in section 257(1)(a) of the Companies Act 1993 have been sent or delivered to the Registrar, thereby completing the liquidation pursuant to section 249 of the Act.

Unless, pursuant to section 321 of the Act, written objection to the removal is delivered to the Registrar by 30 April 2008 (being a date not less than 20 working days after the date of this notice), the Registrar is obliged to remove the company from the Register.

Dated at Auckland this 28th day of March 2008.

L. G. CHILCOTT, Liquidator.

ds2151

New Zealand Winemakers Centre Limited (in liquidation)

Public Notice of Intention to Remove Company From the Register

The Companies Act 1993

Notice is hereby given that, pursuant to section 318(1)(e) of the Companies Act 1993, the Registrar at Auckland shall remove New Zealand Winemakers Centre Limited (in liquidation), whose registered office is situated at Level 6, 51–53 Shortland Street, Auckland, from the New Zealand Register on the grounds that the documents referred to in section 257(1)(a) of the Companies Act 1993 have been sent or delivered to the Registrar of Companies, thereby completing the liquidation pursuant to section 249 of the Act.

Unless, pursuant to section 321 of the Act, written objection to the removal is delivered to the Registrar by 6 May 2008 (being a date not less than 20 working days after the date of this notice), the Registrar is obliged to remove the company from the Register.

Dated at Auckland this 3rd day of April 2008.

GLEN DAVID GERNHOEFER, Liquidator, New Zealand Winemakers Centre Limited (in liquidation).

Address for Service: WHK Gosling Chapman Partnership, Level 6, WHK Gosling Chapman Tower, 51–53 Shortland Street, Auckland 1010. *Postal Address:* PO Box 158, Auckland 1140. Telephone: (09) 303 4586. Facsimile: (09) 309 1198.

Enquiries to: Lisa McGowan. Telephone: (09) 968 8521.

Note: The liquidation is a result of the restructuring of the affairs of the shareholder.

ds2054

Namco Industries Limited (in liquidation)

Public Notice of Intention to Remove Company From the Register

The Companies Act 1993

Notice is hereby given that, pursuant to section 318(1)(e) of the Companies Act 1993, the Registrar at Auckland shall remove Namco Industries Limited (in liquidation), whose registered office is situated at Level 6, 51–53 Shortland Street, Auckland, from the New Zealand Register on the grounds that the documents referred to in section 257(1)(a)

of the Companies Act 1993 have been sent or delivered to the Registrar of Companies, thereby completing the liquidation pursuant to section 249 of the Act.

Unless, pursuant to section 321 of the Act, written objection to the removal is delivered to the Registrar by 6 May 2008 (being a date not less than 20 working days after the date of this notice), the Registrar is obliged to remove the company from the Register.

Dated this 3rd day of April 2008.

GLEN DAVID GERNHOEFER and GARY NOEL HITCHCOCK, Liquidators.

Address for Service: WHK Gosling Chapman Partnership, Level 6, WHK Gosling Chapman Tower, 51–53 Shortland Street, Auckland 1010. *Postal Address:* PO Box 158, Auckland 1140. Telephone: (09) 303 4586. Facsimile: (09) 309 1198.

Enquiries to: Lisa McGowan. Telephone: (09) 968 8521.

Note: This company is solvent and the liquidation is a result of the restructuring of the affairs of the shareholders.

ds2110

CESSATION OF BUSINESS IN NEW ZEALAND

Designware Consulting Pty Ltd

Notice of Intention to Cease Carrying on Business in New Zealand

Notice is hereby given, pursuant to section 341(1)(a) of the Companies Act 1993, that Designware Consulting Pty Ltd intends to cease carrying on business in New Zealand on 30 June 2008.

Address for Service: Nick Duke, 3 Rountree Street, Ilam, Christchurch 8041.

cb2156

WHK Gosling Chapman Tower, 51–53 Shortland Street, Auckland 1010. *Postal Address:* PO Box 158, Auckland 1140. Telephone: (09) 303 4586. Facsimile: (09) 309 1198.

Enquiries to: Lisa McGowan. Telephone: (09) 968 8521.

cb2053

Somnio Pty Limited (formerly **Primex Products Pty Ltd**)

Notice of Intention to Cease to Carry on Business in New Zealand

Company No.: 1290864

Notice is hereby given that the company intends to cease to carry on business in New Zealand and proposes to apply to the Registrar of Companies, pursuant to section 341(1) of the Companies Act 1993, for the removal of Somnio Pty Limited from the New Zealand Overseas Register.

Unless written objection to such removal is sent or delivered to the Registrar at Auckland within 3 months from the date of this notice, the Registrar may remove the company from the Register.

Dated this 25th day of March 2008.

KEVIN DAVID PITFIELD, Applicant.

The Address and Telephone Number to Which, During Normal Business Hours, Enquiries May be Directed by a Creditor or Member: Staples Rodway Limited, Chartered Accountants, PO Box 3899, Auckland. Telephone: (09) 309 0463.

cb2086

APPLICATIONS FOR WINDING UP / LIQUIDATIONS

Advertisement of Application for Putting Company into Liquidation

Take notice that on 4 March 2008, an application for putting **B Q Holdings Limited** into liquidation by the High Court was filed in the High Court at Christchurch.

The application is to be heard before the High Court at Christchurch on 14 April 2008 at 10.00am.

Any person, other than the defendant company, who wishes to appear on the hearing of the application must file an

appearance not later than the second working day before that day.

The plaintiff is **Blue Pacific Seafoods Limited**, whose address for service is at the offices of Duncan Cotterill, Level 9, Clarendon Tower, corner of Worcester Street and Oxford Terrace, Christchurch.

Further particulars may be obtained from the office of the Court or from the plaintiff or the plaintiff's solicitor.

Alice LYSAGHT, Counsel for the Plaintiff.

aw2235

Advertisement of Application for Putting Company into Liquidation

CIV-2008-404-1162

Take notice that on Friday, 29 February 2008, an application for putting **Transpread International Limited** into liquidation by the High Court was filed in the High Court at Auckland.

The application is to be heard before the High Court at Auckland on Friday, 6 June 2008 at 10.45am.

Any person, other than the defendant company, who wishes to appear on the hearing of the application must file an appearance not later than the second working day before that day.

The plaintiff is **Computation Limited**, whose solicitor is Malcolm Whitlock, whose address for service is at the offices of Debt Recovery Group NZ Limited, Level 5, 5 Short Street, Newmarket, Auckland. *Postal Address:* PO Box 99675, Newmarket, Auckland.

Further particulars may be obtained from the office of the Court or from the plaintiff or the plaintiff's solicitor.

MALCOLM WHITLOCK, Solicitor for the Plaintiff.

aw2136

Advertisement of Application for Putting Company into Liquidation

CIV-2007-485-1903

Take notice that on Tuesday, 28 August 2007, an application for putting **Caprice Acquisitions Limited** into liquidation by the High Court was filed in the High Court at Wellington.

The application is to be heard before the High Court at Wellington on Monday, 28 April 2008 at 10.00am.

Any person, other than the defendant company, who wishes to appear on the hearing of the application must file an appearance not later than the second working day before that date.

The plaintiff is **Lindsay Martin Sweeney**, whose address for service is at the offices of Cavell Leitch Pringle & Boyle, Solicitors, Level 15, Clarendon Tower, corner of Worcester Street and Oxford Terrace (PO Box 799), Christchurch. Telephone: (03) 379 9940. Facsimile: (03) 379 2408.

Further particulars may be obtained from the office of the Court or from the plaintiff's solicitor.

OWEN GODFREY PAULSEN, Solicitor for the Plaintiff.

aw2163

Advertisement of Application for Putting Company into Liquidation

Take notice that on 29 February 2008, an application for putting **Papakura Liquor Limited** into liquidation by the High Court was filed in the High Court at Auckland.

The application is to be heard before the High Court at Auckland on 30 May 2008 at 10.45am.

Any person, other than the defendant company, who wishes to appear on the hearing of the application must file an appearance not later than the second working day before that day.

The plaintiff is **Westpac New Zealand Limited**, whose address for service is at Simpson Grierson, Solicitors, Level 27, 88 Shortland Street, Auckland.

Further particulars may be obtained from the office of the Court or from the plaintiff or the plaintiff's solicitor.

M. V. ROBINSON, Solicitor for the Plaintiff.

aw2146

Advertisement of Application for Putting Company into Liquidation by the Court

In the High Court of New Zealand, Auckland Registry

CIV-2007-404-7463

In the matter of the Companies Act 1993, between **Ross Bush** and **Suzanne Bush** (trading as **R & S Bush**), of Muritai Terrace, Christchurch, bricklayers—*Plaintiffs*:

And—Shire Developments No 4 Limited, a duly incorporated company having its registered office c/o Ross Melville PKF, Level 5, 50 Anzac Avenue, Auckland—*Defendant*:

Take notice that on 29 November 2007, an application for putting **Shire Developments No 4 Limited** into liquidation by the High Court was filed in the High Court at Auckland.

The application is to be heard before the High Court at Auckland on Thursday, 24 April 2008 at 10.00am.

Any person, other than the defendant company, who wishes to appear on the hearing of the application must file an appearance not later than the second working day before that day.

The plaintiffs are **Ross Bush** and **Suzanne Bush** (trading as **R & S Bush**), whose address for service is at the offices of R. A. Fraser & Associates, Solicitors, Level 2, 151 Worcester Street (PO Box 163), Christchurch.

Further particulars may be obtained from the office of the Court or from the plaintiffs' solicitor.

A. M. O'CONNOR, Solicitor for the Plaintiffs.

aw2062

Advertisement of Application for Putting Company into Liquidation by the Court

CIV-2008-488-124

Take notice that on 22 February 2008, an application for putting **Quick Freight Limited** into liquidation by the High Court was filed in the High Court at Whangarei.

The application is to be heard before the High Court at Whangarei on 28 April 2008 at 10.00am.

Any person, other than the defendant company, who wishes to appear on the hearing of the application must file an appearance not later than the second working day before that day.

The plaintiff is **Far North Fuels Limited**, whose address for service is at the offices of Whitlock & Co., c/o Level 2, Baycorp House, 15 Hopetoun Street, Auckland.

Further particulars may be obtained from the office of the Court or from the plaintiff or the plaintiff's solicitor.

MALCOLM DAVID WHITLOCK, Solicitor for the Plaintiff.

aw2148

Advertisement of Application for Putting Company into Liquidation by the Court

CIV-2008-404-713

Take notice that on 5 February 2008, an application for putting **Office Elves Group Limited** into liquidation by the High Court was filed in the High Court at Auckland.

The application is to be heard before the High Court at Auckland on 4 June 2008 at 10.00am.

Any person, other than the defendant company, who wishes to appear on the hearing of the application must file an appearance not later than the second working day before that day.

The plaintiff is **Albany Executive Recruitment Limited**, whose address for service is at the offices of Whitlock & Co., c/o Level 2, Baycorp House, 15 Hopetoun Street, Auckland.

Further particulars may be obtained from the office of the Court or from the plaintiff or the plaintiff's solicitor.

MALCOLM DAVID WHITLOCK, Solicitor for the Plaintiff.
aw2150

Advertisement of Application for Putting Company into Liquidation by the Court

CIV-2008-404-883

Take notice that on 15 February 2008, an application for putting **Jaytech Intelligent Systems Limited** into liquidation by the High Court was filed in the High Court at Auckland.

The application is to be heard before the High Court at Auckland on 30 May 2008 at 10.00am.

Any person, other than the defendant company, who wishes to appear on the hearing of the application must file an appearance not later than the second working day before that date.

The plaintiff is **Security Merchants Limited**, whose address for service is at the offices of Whitlock & Co., c/o Level 2, Baycorp House, 15 Hopetoun Street, Auckland.

Further particulars may be obtained from the office of the Court or from the plaintiff or the plaintiff's solicitor.

MALCOLM DAVID WHITLOCK, Solicitor for the Plaintiff.
aw2149

Advertisement of Application for Putting Company into Liquidation

CIV-2007-404-7637

Take notice that on 5 December 2007, an application for putting **Dotcard (Australasia) Limited** into liquidation by the High Court was filed in the High Court at Auckland.

The application is to be heard before the High Court at Auckland on 9 April 2008 at 10.45am.

Any person, other than the defendant company, who wishes to appear on the hearing of the application must file an appearance not later than the second working day before that date.

The plaintiff is **Bell Gully**, whose address for service is Level 22, Vero Centre, 48 Shortland Street, Auckland (*Attention: D. F. Elliott*).

Further particulars may be obtained from the office of the Court or from the plaintiff.

MURRAY JOHN TINGEY, Solicitor for the Plaintiff.
aw2109

Advertisement of Application for Putting Company into Liquidation

CIV-2008-404-1440

Take notice that on 13 March 2008, an application for putting **Merlot Homes Limited** into liquidation by the High Court was filed in the High Court at Auckland.

The application is to be heard before the High Court at Auckland on 20 June 2008 at 10.45am.

Any person, other than the defendant company, who wishes to appear on the hearing of the application must file an appearance not later than the second working day before that date.

The plaintiff is **EFS One Limited**, whose address for service is at the offices of its solicitors, Fortune Manning, gen-i Tower, Level 12, 66 Wyndham Street (PO Box 4139), Auckland.

Further particulars may be obtained from the office of the Court or from the plaintiff or the plaintiff's solicitor.

M. M. EDWARDS, Solicitor for the Plaintiff.
aw2079

Advertisement of Application for Winding Up of Company

Take notice that on 6 March 2008, an application for the winding up of **Englefield Enterprises Limited** (in receivership) by the High Court was filed in the High Court at Christchurch.

The application is to be heard before the High Court at Christchurch on Monday, 14 April 2008 at 10.00am.

Any person, other than the defendant company, who wishes to appear on the hearing of the application must file an appearance no later than the second working day before that date.

The plaintiff is **Connolly Trading Limited** (trading as **Angus Meats**), whose address for service is at the offices of its agent, L. A. Clement, PO Box 36636, Merivale, Christchurch. Telephone: (03) 354 2920. Facsimile: (03) 354 2930.

Further particulars may be obtained from the office of the Court or from the plaintiff or the plaintiff's agent.

L. A. CLEMENT, Agent for the Plaintiff.
aw2077

Advertisement of Application for Putting Company into Liquidation

CIV-2008-404-874

Take notice that on 15 February 2008, an application for putting **Harvest Builders Limited** into liquidation by the High Court was filed in the High Court at Auckland.

The application is to be heard before the High Court at Auckland on 6 June 2008 at 10.00am.

Any person, other than the defendant company, who wishes to appear on the hearing of the application must file an appearance not later than the second working day before that date.

The plaintiff is **Bunnings Limited** (trading as **Benchmark Building Supplies**), whose address for service is at the offices of Craig Griffin & Lord, Solicitors, 187 Mt Eden Road, Mt Eden, Auckland. *Postal Address: PO Box 9049, Newmarket, Auckland.*

Further particulars may be obtained from the office of the Court or from the plaintiff or the plaintiff's solicitor.

C. N. LORD, Solicitor for the Plaintiff.
aw2182

Advertisement of Application for Putting Company into Liquidation by the Court

CIV-2007-404-6899

Take notice that on 8 November 2007, an application for putting **New Zealand Power Construction Limited** into liquidation by the High Court was filed in the High Court at Auckland.

The application is to be heard before the High Court at Auckland on Friday, 11 April 2008 at 10.00am.

Any person, other than the defendant company, who wishes to appear on the hearing of the application must file an appearance not later than the second working day before that date.

The plaintiff is **Transnet NZ Limited**, whose address for service is at the offices of Stafford Klaassen, Solicitors, 1 Kimberley Road (PO Box 29185), Epsom, Auckland.

Further particulars may be obtained from the office of the Court or from the plaintiff or the plaintiff's solicitor.

ANDREW KLAASSEN, Solicitor for the Plaintiff.
aw2223

Advertisement of Application for Putting Company into Liquidation

CIV-2007-404-7663

Take notice that on 29 November 2007, an application for putting **Rojace Enterprises Limited** into liquidation by the High Court was filed in the High Court at Auckland.

The application is to be heard before the High Court at Auckland on Friday, 11 April 2008 at 10.45am.

Any person, other than the defendant company, who wishes to appear on the hearing of the application must file an appearance not later than the second working day before that day.

The plaintiff is **KCR Produce Limited**, whose solicitor is Donnell and Associates, whose address for service is at the offices of Donnell and Associates, Level 1, Unit 20, 18 Link Drive, Wairau Park, North Shore City 0627. *Postal Address:* PO Box 334050, Sunnynook, North Shore City 0743.

Further particulars may be obtained from the office of the Court or from the plaintiff or the plaintiff's solicitor.

FIONA ROBYN MEADOWS-FLOWER, Solicitor for the Plaintiff.

aw2234

Advertisement of Application for Putting Company into Liquidation

CIV-2007-404-7673

Take notice that on 29 November 2007, an application for putting **Cutting Edge (NZ) Limited** into liquidation by the High Court was filed in the High Court at Auckland.

The application is to be heard before the High Court at Auckland on Friday, 18 April 2008 at 10.45am.

Any person, other than the defendant company, who wishes to appear on the hearing of the application must file an appearance not later than the second working day before that day.

The plaintiff is **KCR Produce Limited**, whose solicitor is Donnell and Associates, whose address for service is at the offices of Donnell and Associates, Level 1, Unit 20, 18 Link Drive, Wairau Park, North Shore City 0627. *Postal Address:* PO Box 334050, Sunnynook, North Shore City 0743.

Further particulars may be obtained from the office of the Court or from the plaintiff or the plaintiff's solicitor.

FIONA ROBYN MEADOWS-FLOWER, Solicitor for the Plaintiff.

aw2233

Advertisement of Application for Putting Trust into Liquidation

Take notice that on 12 September 2005, an application for putting **Monte Cecilia House Trust** into liquidation by the High Court was filed in the High Court at Auckland.

The application is to be heard before the High Court at Auckland on Friday, 11 July 2008 at 10.45am.

Any person, other than the defendant trust, who wishes to appear on the hearing of the application must file an appearance not later than the second working day before that day.

The plaintiff is **Monte Cecilia House Trust**, whose address for service is care of Foy & Halse, Solicitors, 145 Manukau Road, Auckland. *Postal Address:* PO Box 26218, Epsom, Auckland 1344. Telephone: (09) 638 7151. Facsimile: (09) 630 2782.

Further particulars may be obtained from the office of the Court or from the plaintiff's solicitor.

JANE BOYCE, Solicitor for the Plaintiff.

aw2162

Advertisement of Application for Putting Company into Liquidation

CIV-2008-485-518

Take notice that on 13 March 2008, an application for putting **IJ Contractors Limited** into liquidation by the High Court was filed in the High Court at Wellington.

The application is to be heard before the High Court at Wellington on Monday, 28 April 2008 at 10.00am.

Any person, other than the defendant company, who wishes to appear on the hearing of the application must file an appearance not later than the second working day before that day.

The plaintiff is **Steel & Tube Holdings Limited**, whose address for service is c/o Walters Law, Level 23, Qantas House, 191 Queen Street, Auckland. *Postal Address:* PO Box 1972, Shortland Street, Auckland. Enquiries should be directed to Merran Chisholm on (09) 921 0225 or email merran.chisholm@walterslaw.co.nz

Further particulars may be obtained from the office of the Court or from the plaintiff or the plaintiff's solicitor.

MERRAN A. CHISHOLM, Solicitor for the Plaintiff.

aw2074

Advertisement of Application for Putting Company into Liquidation

CIV-2007-404-7557

Take notice that on 3 December 2007, an application for putting **Scotia Trustee Limited** into liquidation by the High Court was filed in the High Court at Auckland.

The application is to be heard before the High Court at Auckland on 11 April 2008 at 10.45am.

Any person, other than the defendant company, who wishes to appear on the hearing of the application must file an appearance not later than the second working day before that date.

The plaintiff is **Firth** (a division of **Fletcher Concrete & Infrastructure Limited**), whose address for service is at Credit Consultants Debt Services NZ Limited, Level 3, 3-9 Church Street (PO Box 213 or DX SX 10069), Wellington. Telephone: (04) 470 5972.

Further particulars may be obtained from the office of the Court or from the plaintiff or the plaintiff's solicitor.

DIANNE S. LESTER, Solicitor for the Plaintiff.

aw2014

Advertisement of Application for Putting Company into Liquidation

CIV-2008-442-109

Take notice that on 13 March 2008, an application for putting **Waimea Tyres Limited** into liquidation by the High Court was filed in the High Court at Nelson.

The application is to be heard before the High Court at Nelson on 17 April 2008 at 10.00am.

Any person, other than the defendant company, who wishes to appear on the hearing of the application must file an appearance not later than the second working day before that date.

The plaintiff is **O.T.R. International Limited**, whose address for service is at Credit Consultants Debt Services NZ Limited, Level 3, 3-9 Church Street (PO Box 213 or DX SX 10069), Wellington. Telephone: (04) 470 5972.

Further particulars may be obtained from the office of the Court or from the plaintiff or the plaintiff's solicitor.

DIANNE S. LESTER, Solicitor for the Plaintiff.

aw2190



Advertisement of Application for Putting Company into Liquidation

CIV-2007-404-5906

Take notice that on 19 September 2007, an application for putting **New Lynn Tyres & Car Repairs Limited** into liquidation by the High Court was filed in the High Court at Auckland.

The application is to be heard before the High Court at Auckland on Friday, 18 April 2008 at 10.45am.

Any person, other than the defendant company, who wishes to appear on the hearing of the application must file an appearance not later than the second working day before that day.

The plaintiff is the **Commissioner of Inland Revenue**, whose address for service is Inland Revenue Department, Legal and Technical Services, 5-7 Byron Avenue (PO Box 33150), Takapuna, Auckland. Telephone: (09) 984 1309. Facsimile: (09) 984 3116.

Further particulars may be obtained from the office of the Court or from the plaintiff's solicitor, Kathleena Hemotitaha Smith, contact details as noted above.

KATHLEENA HEMOTITAHA SMITH, Solicitor for the Plaintiff.

aw2089

Advertisement of Application for Putting Company into Liquidation

CIV-2007-404-6954

Take notice that on 13 November 2007, an application for putting **Allbanx Mortgages Limited** into liquidation by the High Court was filed in the High Court at Auckland.

The application is to be heard before the High Court at Auckland on Friday, 18 April 2008 at 10.00am.

Any person, other than the defendant company, who wishes to appear on the hearing of the application must file an appearance not later than the second working day before that day.

The plaintiff is the **Commissioner of Inland Revenue**, whose address for service is Inland Revenue Department, Legal and Technical Services, 5-7 Byron Avenue (PO Box 33150), Takapuna, Auckland. Telephone: (09) 984 1514. Facsimile: (09) 984 3116.

Further particulars may be obtained from the office of the Court or from the plaintiff's solicitor, Michael Kinlim Yan, contact details as noted above.

MICHAEL KINLIM YAN, Solicitor for the Plaintiff.

aw2167

Advertisement of Application for Putting Company into Liquidation

CIV-2007-404-6956

Take notice that on 13 November 2007, an application for putting **Orapiu Bay Resort Limited** into liquidation by the High Court was filed in the High Court at Auckland.

The application is to be heard before the High Court at Auckland on Friday, 18 April 2008 at 10.00am.

Any person, other than the defendant company, who wishes to appear on the hearing of the application must file an appearance not later than the second working day before that day.

The plaintiff is the **Commissioner of Inland Revenue**, whose address for service is Inland Revenue Department, Legal and Technical Services, 5-7 Byron Avenue (PO Box

33150), Takapuna, Auckland. Telephone: (09) 984 1514. Facsimile: (09) 984 3116.

Further particulars may be obtained from the office of the Court or from the plaintiff's solicitor, Michael Kinlim Yan, contact details as noted above.

MICHAEL KINLIM YAN, Solicitor for the Plaintiff.

aw2169

Advertisement of Application for Putting Company into Liquidation

CIV-2007-404-7227

Take notice that on 22 November 2007, an application for putting **Ashby Holdings Limited** into liquidation by the High Court was filed in the High Court at Auckland.

The application is to be heard before the High Court at Auckland on Friday, 11 April 2008 at 10.00am.

Any person, other than the defendant company, who wishes to appear on the hearing of the application must file an appearance not later than the second working day before that day.

The plaintiff is the **Commissioner of Inland Revenue**, whose address for service is Inland Revenue Department, Legal and Technical Services, 5-7 Byron Avenue (PO Box 33150), Takapuna, Auckland. Telephone: (09) 984 1514. Facsimile: (09) 984 3116.

Further particulars may be obtained from the office of the Court or from the plaintiff's solicitor, Michael Kinlim Yan, contact details as noted above.

MICHAEL KINLIM YAN, Solicitor for the Plaintiff.

aw2166

Advertisement of Application for Putting Company into Liquidation

CIV-2007-404-7344

Take notice that on 27 November 2007, an application for putting **G W & S B Design & Marketing Limited** into liquidation by the High Court was filed in the High Court at Auckland.

The application is to be heard before the High Court at Auckland on Friday, 18 April 2008 at 10.00am.

Any person, other than the defendant company, who wishes to appear on the hearing of the application must file an appearance not later than the second working day before that day.

The plaintiff is the **Commissioner of Inland Revenue**, whose address for service is Inland Revenue Department, Legal and Technical Services, 5-7 Byron Avenue (PO Box 33150), Takapuna, Auckland. Telephone: (09) 984 1514. Facsimile: (09) 984 3116.

Further particulars may be obtained from the office of the Court or from the plaintiff's solicitor, Michael Kinlim Yan, contact details as noted above.

MICHAEL KINLIM YAN, Solicitor for the Plaintiff.

aw2168

Advertisement of Application for Putting Company into Liquidation

CIV-2007-404-7349

Take notice that on 27 November 2007, an application for putting **Sawgrass Developments Limited** into liquidation by the High Court was filed in the High Court at Auckland.

The application is to be heard before the High Court at Auckland on Thursday, 24 April 2008 at 10.00am.

Any person, other than the defendant company, who wishes to appear on the hearing of the application must file an appearance not later than the second working day before that day.

The plaintiff is the **Commissioner of Inland Revenue**, whose address for service is Inland Revenue Department, Legal and Technical Services, 5-7 Byron Avenue (PO Box 33150), Takapuna, Auckland. Telephone: (09) 984 1514. Facsimile: (09) 984 3116.

Further particulars may be obtained from the office of the Court or from the plaintiff's solicitor, Michael Kinlim Yan, contact details as noted above.

MICHAEL KINLIM YAN, Solicitor for the Plaintiff.

aw2171

Advertisement of Application for Putting Company into Liquidation

CIV-2007-404-7596

Take notice that on 5 December 2007, an application for putting **J W Lepper Limited** into liquidation by the High Court was filed in the High Court at Auckland.

The application is to be heard before the High Court at Auckland on Friday, 18 April 2008 at 10.45am.

Any person, other than the defendant company, who wishes to appear on the hearing of the application must file an appearance not later than the second working day before that day.

The plaintiff is the **Commissioner of Inland Revenue**, whose address for service is Inland Revenue Department, Legal and Technical Services, 5-7 Byron Avenue (PO Box 33150), Takapuna, Auckland. Telephone: (09) 984 1514. Facsimile: (09) 984 3116.

Further particulars may be obtained from the office of the Court or from the plaintiff's solicitor, Michael Kinlim Yan, contact details as noted above.

MICHAEL KINLIM YAN, Solicitor for the Plaintiff.

aw2170

Advertisement of Application for Putting Company into Liquidation

CIV-2007-404-7602

Take notice that on 5 December 2007, an application for putting **Wayne Blake Builders Limited** into liquidation by the High Court was filed in the High Court at Auckland.

The application is to be heard before the High Court at Auckland on Thursday, 24 April 2008 at 10.45am.

Any person, other than the defendant company, who wishes to appear on the hearing of the application must file an appearance not later than the second working day before that day.

The plaintiff is the **Commissioner of Inland Revenue**, whose address for service is Inland Revenue Department, Legal and Technical Services, 5-7 Byron Avenue (PO Box 33150), Takapuna, Auckland. Telephone: (09) 984 1514. Facsimile: (09) 984 3116.

Further particulars may be obtained from the office of the Court or from the plaintiff's solicitor, Michael Kinlim Yan, contact details as noted above.

MICHAEL KINLIM YAN, Solicitor for the Plaintiff.

aw2172

Advertisement of Application for Putting Company into Liquidation

CIV-2007-404-7042

Take notice that on 15 November 2007, an application for putting **Gary Smith Bricklayers Limited** into liquidation by the High Court was filed in the High Court at Auckland.

The application is to be heard before the High Court at Auckland on Friday, 18 April 2008 at 10.00am.

Any person, other than the defendant company, who wishes to appear on the hearing of the application must file an appearance not later than the second working day before that day.

The plaintiff is the **Commissioner of Inland Revenue**, whose address for service is Inland Revenue Department, Legal and Technical Services, 17 Putney Way (PO Box 76198), Manukau, Auckland 2241. Telephone: (09) 985 7274. Facsimile: (09) 985 9473.

Further particulars may be obtained from the office of the Court or from the plaintiff's solicitor, Sandra Joy North, contact details as noted above.

SANDRA JOY NORTH, Solicitor for the Plaintiff.

aw1943

Advertisement of Application for Putting Company into Liquidation

CIV-2008-404-7572

Take notice that on 4 December 2007, an application for putting **Domani Group Limited** into liquidation by the High Court was filed in the High Court at Auckland.

The application is to be heard before the High Court at Auckland on Friday, 18 April 2008 at 10.45am.

Any person, other than the defendant company, who wishes to appear on the hearing of the application must file an appearance not later than the second working day before that day.

The plaintiff is the **Commissioner of Inland Revenue**, whose address for service is Inland Revenue Department, Legal and Technical Services, 17 Putney Way (PO Box 76198), Manukau, Auckland 2241. Telephone: (09) 985 7274. Facsimile: (09) 985 9473.

Further particulars may be obtained from the office of the Court or from the plaintiff's solicitor, Sandra Joy North, contact details as noted above.

SANDRA JOY NORTH, Solicitor for the Plaintiff.

aw1946

Advertisement of Application for Putting Company into Liquidation

CIV-2007-404-7573

Take notice that on 4 December 2007, an application for putting **Parnell Property Maintenance Limited** into liquidation by the High Court was filed in the High Court at Auckland.

The application is to be heard before the High Court at Auckland on Friday, 18 April 2008 at 10.45am.

Any person, other than the defendant company, who wishes to appear on the hearing of the application must file an appearance not later than the second working day before that day.

The plaintiff is the **Commissioner of Inland Revenue**, whose address for service is Inland Revenue Department,



Legal and Technical Services, 17 Putney Way (PO Box 76198), Manukau, Auckland 2241. Telephone: (09) 985 7274. Facsimile: (09) 985 9473.

Further particulars may be obtained from the office of the Court or from the plaintiff's solicitor, Sandra Joy North, contact details as noted above.

SANDRA JOY NORTH, Solicitor for the Plaintiff.

aw2030

Advertisement of Application for Putting Company into Liquidation

CIV-2008-406-30

Take notice that on 7 February 2008, an application for putting **Kiwi Viticulture Limited** into liquidation by the High Court was filed in the High Court at Blenheim.

The application is to be heard before the High Court at Blenheim on Wednesday, 16 April 2008 at 10.00am.

Any person, other than the defendant company, who wishes to appear on the hearing of the application must file an appearance not later than the second working day before that day.

The plaintiff is the **Commissioner of Inland Revenue**, whose address for service is Inland Revenue Department, Legal and Technical Services, 17 Putney Way (PO Box 76198), Manukau, Auckland 2241. Telephone: (09) 985 7274. Facsimile: (09) 985 9473.

Further particulars may be obtained from the office of the Court or from the plaintiff's solicitor, Sandra Joy North, contact details as noted above.

SANDRA JOY NORTH, Solicitor for the Plaintiff.

aw1944

Advertisement of Application for Putting Company into Liquidation

CIV-2008-406-47

Take notice that on 27 February 2008, an application for putting **Devoted Vine Limited** into liquidation by the High Court was filed in the High Court at Blenheim.

The application is to be heard before the High Court at Blenheim on Wednesday, 16 April 2008 at 10.00am.

Any person, other than the defendant company, who wishes to appear on the hearing of the application must file an appearance not later than the second working day before that day.

The plaintiff is the **Commissioner of Inland Revenue**, whose address for service is Inland Revenue Department, Legal and Technical Services, 17 Putney Way (PO Box 76198), Manukau, Auckland 2241. Telephone: (09) 985 7274. Facsimile: (09) 985 9473.

Further particulars may be obtained from the office of the Court or from the plaintiff's solicitor, Sandra Joy North, contact details as noted above.

SANDRA JOY NORTH, Solicitor for the Plaintiff.

aw1945

Advertisement of Application for Putting Company into Liquidation

CIV-2008-463-34

Take notice that on 25 January 2008, an application for putting **Cardno Television Productions Limited** into liquidation by the High Court was filed in the High Court at Rotorua.

The application is to be heard before the High Court at Rotorua on Monday, 21 April 2008 at 10.45am.

Any person, other than the defendant company, who wishes to appear on the hearing of the application must file an appearance not later than the second working day before that day.

The plaintiff is the **Commissioner of Inland Revenue**, whose address for service is Inland Revenue Department, Legal and Technical Services, 1 Bryce Street (PO Box 432), Hamilton. Telephone: (07) 959 0416. Facsimile: (07) 959 7614.

Further particulars may be obtained from the office of the Court or from the plaintiff by contacting H. Malthus on telephone (07) 959 0229 in the first instance or the plaintiff's solicitor, Rachel L. Scott, contact details as noted above.

RACHEL L. SCOTT, Solicitor for the Plaintiff.

aw2147

Advertisement of Application for Putting Company into Liquidation

CIV-2007-476-640

Take notice that on 27 November 2007, an application for putting **Pretton Limited** into liquidation by the High Court was filed in the High Court at Timaru.

The application is to be heard before the High Court at Timaru on 15 April 2008 at 2.15pm.

Any person, other than the defendant company, who wishes to appear on the hearing of the application must file an appearance not later than the second working day before that day.

The plaintiff is the **Commissioner of Inland Revenue**, whose address for service is Inland Revenue Department, Legal and Technical Services, 7-27 Waterloo Quay (PO Box 1462), Wellington. Telephone: (04) 890 0415. Facsimile: (04) 890 0009.

Further particulars may be obtained from the office of the Court or from the plaintiff's solicitor, Deanne Myree Guidera, contact details as noted above.

DEANNE MYREE GUIDERA, Solicitor for the Plaintiff.

aw1942

Advertisement of Application for Putting Company into Liquidation

CIV-2008-485-439

Take notice that on 5 March 2008, an application for putting **D.J.R. Limited** into liquidation by the High Court was filed in the High Court at Wellington.

The application is to be heard before the High Court at Wellington on 14 April 2008 at 10.00am.

Any person, other than the defendant company, who wishes to appear on the hearing of the application must file an appearance not later than the second working day before that day.

The plaintiff is the **Commissioner of Inland Revenue**, whose address for service is Inland Revenue Department, Legal and Technical Services, 7-27 Waterloo Quay (PO Box 1462), Wellington. Telephone: (04) 890 1127. Facsimile: (04) 890 0009.

Further particulars may be obtained from the office of the Court or from the plaintiff's solicitor, Julia Marie Snelson, contact details as noted above.

JULIA MARIE SNELSON, Solicitor for the Plaintiff.

aw2200

Advertisement of Application for Putting Company into Liquidation

CIV-2007-406-302

Take notice that on 17 December 2007, an application for putting **Wine Reach Services Limited** into liquidation by the High Court was filed in the High Court at Blenheim.

The application is to be heard before the High Court at Blenheim on Wednesday, 16 April 2008 at 10.00am.

Any person, other than the defendant company, who wishes to appear on the hearing of the application must file an appearance not later than the second working day before that day.

The plaintiff is the **Commissioner of Inland Revenue**, whose address for service is Inland Revenue Department, Legal and Technical Services, First Floor Reception, 224 Cashel Street (PO Box 1782), Christchurch 8140. Telephone: (03) 968 0807. Facsimile: (03) 977 9853.

Further particulars may be obtained from the office of the Court or from the plaintiff's solicitor, Julie Newton, contact details as noted above.

JULIE NEWTON, Solicitor for the Plaintiff.

aw2143

Advertisement of Application for Putting Company into Liquidation

CIV-2007-406-303

Take notice that on 17 December 2007, an application for putting **AMMA Corp Limited** into liquidation by the High Court was filed in the High Court at Blenheim.

The application is to be heard before the High Court at Blenheim on Wednesday, 16 April 2008 at 10.00am.

Any person, other than the defendant company, who wishes to appear on the hearing of the application must file an appearance not later than the second working day before that day.

Provenco Group Limited and Cadmus Technology Limited

Public Notice of Amalgamation Proposal

Pursuant to Section 221(4) of the Companies Act 1993

The boards of **Provenco Group Limited** and **Cadmus Technology Limited** give notice of the proposed amalgamation between **Provenco Group Limited** and **Cadmus Technology Limited** (each an amalgamating company).

Provenco Group Limited is intended to continue as the amalgamated company.

Following the amalgamation, it is proposed that the merged company will change its name to a name yet to be determined.

Copies of the amalgamation proposal are available for inspection by any shareholder or creditor of an amalgamating company, or any person to whom an amalgamating company is under an obligation, at the registered offices of each amalgamating company detailed below, during normal business hours.

Any shareholder or creditor of an amalgamating company, or any person to whom an amalgamating company is under an obligation, is entitled to be provided free of charge with a copy of the amalgamation proposal by writing to the registered office of that amalgamating company, detailed below, requesting a copy.

The plaintiff is the **Commissioner of Inland Revenue**, whose address for service is Inland Revenue Department, Legal and Technical Services, First Floor Reception, 224 Cashel Street (PO Box 1782), Christchurch 8140. Telephone: (03) 968 0807. Facsimile: (03) 977 9853.

Further particulars may be obtained from the office of the Court or from the plaintiff's solicitor, Julie Newton, contact details as noted above.

JULIE NEWTON, Solicitor for the Plaintiff.

aw2144

Advertisement of Application for Putting Company into Liquidation

CIV-2007-476-590

Take notice that on 7 November 2007, an application for putting **Southern Lakes Engineering Limited** into liquidation by the High Court was filed in the High Court at Timaru.

The application is to be heard before the High Court at Timaru on Tuesday, 15 April 2008 at 2.15pm.

Any person, other than the defendant company, who wishes to appear on the hearing of the application must file an appearance not later than the second working day before that day.

The plaintiff is the **Commissioner of Inland Revenue**, whose address for service is Inland Revenue Department, Legal and Technical Services, First Floor Reception, 224 Cashel Street (PO Box 1782), Christchurch 8140. Telephone: (03) 968 0807. Facsimile: (03) 977 9853.

Further particulars may be obtained from the office of the Court or from the plaintiff's solicitor, Julie Newton, contact details as noted above.

JULIE NEWTON, Solicitor for the Plaintiff.

aw2199

OTHER

The registered office for each amalgamating company is:

Provenco Group Limited, 25 College Hill, Freemans Bay, Auckland.

Cadmus Technology Limited, 182–190 Wairau Road, Glenfield, Auckland.

Dated this 27th day of March 2008.

RICK CHRISTIE, Provenco Chairman.

PETER MAIRE, Cadmus Chairman.

ot2127

Notice Prohibiting Person From Managing Companies

Pursuant to Section 385 of the Companies Act 1993

To: Gary Donald Ashley.

Of: 87 Matipo Road, Mairangi Bay, Auckland.

Pursuant to section 385(3) of the Companies Act 1993, I, Peter Barker, Deputy Registrar of Companies, hereby prohibit **Gary Donald Ashley** from being a director or promoter of, or being concerned in, or taking part, whether directly or indirectly, in the management of any company for a period of five years as from the date of this notice.

Dated at Wellington this 6th day of March 2008.

PETER BARKER, Deputy Registrar of Companies.

ot2065

General Notices

Notice of Entry into Possession of Mortgaged Property

To: **Kingi Peter Stanley Martin and Winifred Martin**,
24 Deanwell Avenue, Hamilton.

In the matter of section 156 of the Property Law Act 2007, and in the matter of mortgage instrument 6894285.5 (South Auckland Registry) (“the mortgage”):

TEA Custodians (Bluestone) Limited (“the mortgagee”) under the mortgage, gives notice as follows:

1. On 19 March 2008, the mortgagee under the mortgage, entered into possession of the mortgaged property.

2. The description of the mortgaged property is Lot 126 DP S13491 in Computer Freehold Register 11A/466 (South Auckland Registry) being the property at **24 Deanwell Avenue, Hamilton**.

3. The address of the mortgagee’s registered office is Level 5, 10 Customhouse Quay, Wellington.

Signed and dated at Auckland this 20th day of March 2008.

JANE STENBERG, on Behalf of the Mortgagee.

Note: This notice is given by Sanderson Weir, Barristers and Solicitors, whose address for service is Level 13, AA Centre, 99 Albert Street, Auckland.

gn2044

Vice Regal

Cabinet Office

Retention of the Title ‘The Honourable’

His Excellency the Governor-General of New Zealand, acting under delegated authority from Her Majesty The Queen, has approved the retention of the title “The Honourable” by

Noel Crossley ANDERSON, D.C.N.Z.M.

on his retirement as a Member of the Supreme Court of New Zealand on 5 May 2008; and

John William HANSEN

on his retirement as a Judge of the High Court of New Zealand on 11 April 2008.

Dated at Wellington this 6th day of March 2008.

vr1682

Departmental Notices

Building and Housing

Building Act 2004

Notice of Appointment

Under section 261(1)(a) of the Building Act 2004, I, Katrina Bach, Chief Executive of the Department of Building and Housing (“the chief executive”), appoint as the product certification accreditation body:

The Joint Accreditation System of Australia and New Zealand (JAS-ANZ), a body corporate established under the Diplomatic Privileges (Joint Accreditation System of Australia and New Zealand) Order 1998, made pursuant to section 9 of the Diplomatic Privileges and Immunities Act 1968.

This appointment is effective from the date below and is revocable by the chief executive under section 261(1)(b) of the Building Act 2004.

The chief executive and JAS-ANZ intend to enter into a separate arrangement to record how they will work together during the term of this appointment.

Dated this 31st day of March 2008.

KATRINA BACH, Chief Executive, Department of Building and Housing.

go2198

Consumer Affairs

Fair Trading Act 1986

Unsafe Goods (Tian Mao Water Colour Paint Sets) Notice 2008

Pursuant to section 31 of the Fair Trading Act 1986, the Minister of Consumer Affairs gives the following notice.

Notice

1. Title—(1) This notice may be cited as the Unsafe Goods (Tian Mao Water Colour Paint Sets) Notice 2008.

(2) This notice is effective from the date of publication in the *New Zealand Gazette*.

2. Certain water colour sets declared to be unsafe goods—The goods described in the Schedule to this notice are declared to be unsafe goods.

Schedule

(a) Water colour paint or painting sets for art and crafts packaged under the name Tian Mao;

(b) water colour paint or painting sets with the product code TM-9018; and

- (c) water colour paint or painting sets for art and crafts featuring the identified logo:



Dated at Wellington this 1st day of April 2008.

JUDITH TIZARD, Minister of Consumer Affairs.

Explanatory Note

This note is not part of the notice but is intended to indicate its general effect.

*Under section 31(2) of the Act, unless it is sooner revoked, the notice remains in force for a period of 18 months after the date of publication in the **New Zealand Gazette**.*

It is an offence under the Fair Trading Act 1986 to supply, or offer to supply, or advertise to supply, goods which are declared to be unsafe goods.

Section 33 of that Act prohibits the importation of such goods into New Zealand.

go2210

Education

Private Schools Conditional Integration Act 1975

Supplementary Integration Agreements

Pursuant to section 10 of the Private Schools Conditional Integration Act 1975, notice is given that supplementary integration agreements have been signed between the Minister of Education on behalf of Her Majesty The Queen, acting through the Group Manager, National Operations, Ministry of Education, pursuant to delegated authority, and the proprietors of the following schools:

St Michael's School, Taita.

St Brendan's School, Heretaunga.

The said supplementary integration agreements were executed on 31 March 2008.

Copies of the supplementary integration agreements are available for inspection without charge by any member of the public at the regional office of the Ministry of Education, 19 Market Grove, Lower Hutt.

Dated at Wellington this 31st day of March 2008.

KATHY PHILLIPS, Group Manager, National Operations.

go2225

Fisheries

Fisheries Act 1996

Fisheries (Seabird Sustainability Measures—Bottom Longlines) Notice (No. 2) 2008 (No. F441)

Pursuant to section 11 of the Fisheries Act 1996, the Minister of Fisheries gives the following notice.

Notice

1. Title—This notice is the Fisheries (Seabird Sustainability Measures—Bottom Longlines) Notice (No. 2) 2008.

2. Commencement—This notice comes into force on 12 April 2008.

3. Interpretation—In this notice, unless the context otherwise requires:

“Act” means the Fisheries Act 1996;

“aerial extent” means the section of the streamer line backbone running from the vessel stern, to where the backbone of the streamer line enters the water;

“bottom longline” means a line to which 7 or more hooks (whether baited or not) are attached, and is sunk using weights;

“hauling” means the period from when line retrieval commences to when all of the hooks are onboard;

“nautical dawn” means the time at sunrise when the centre of the sun is at a depression angle of 12 degrees below the ideal horizon for the location of fishing;

“nautical dusk” means the time at sunset when the centre of the sun is at a depression angle of 12 degrees below the ideal horizon for the location of fishing;

“offal” means solid fish parts, including heads, guts, frames, tails, tentacles and fish trimmings, or parts thereof including minced parts; and

“set”, in relation to a bottom longline, means releasing the bottom longline into the water.

4. Streamer line required—A commercial fisher using bottom longlines as a method of fishing from a vessel 7 metres or greater in overall length must:

(a) carry a streamer line on board the vessel; and

(b) permit inspection of the streamer line at any reasonable time by a fisheries officer or an observer appointed under section 223(2) of the Act.

5. Use of streamer line required during setting of bottom longlines—A streamer line must be used on vessels 7 metres or greater in overall length during the setting of bottom longlines, in accordance with clause 6 of this notice.

6. Streamer line specifications—(1) For vessels over 20 metres in overall length, the streamer line must meet the following specifications:

- (a) The streamer line must be attached to the vessel so that when deployed the baits are protected by the streamer line, even in cross wind;
- (b) the streamer line must be a minimum of 150 metres in length;
- (c) the streamer line must achieve a minimum aerial extent of 50 metres;
- (d) streamers must be brightly coloured;
- (e) streamers must be spaced at a maximum of 5 metres apart, beginning not more than 5 metres from the stern of the vessel and extending along the full aerial extent of the line;
- (f) when deployed, each of the streamers must reach the sea surface in the absence of wind and swell. Streamer length will therefore vary depending on the height of their attachment point above the water; and
- (g) the streamer line must be suspended from a point on the vessel at least 5 metres above the water in the absence of swell.

(2) For vessels 7 metres–20 metres in overall length, the streamer line must meet the following specifications:

- (a) The streamer line must achieve a minimum aerial extent of 50 metres;
- (b) streamers must be brightly coloured;
- (c) streamers must be spaced at a maximum of 5 metres apart, beginning not more than 5 metres from the stern of the vessel and extending along the full aerial extent of the line;
- (d) when deployed, each of the streamers must reach the sea surface in the absence of wind and swell. Streamer length will therefore vary depending on the height of their attachment point above the water; and
- (e) the streamer line must be suspended from a point on the vessel at least 5 metres above the water in the absence of swell.

(3) The specifications in subclauses (1) and (2) do not apply to additional or secondary seabird scaring devices fishers may choose to use (such as a second tori or streamer line).

7. Restrictions on use of bottom longlines—No commercial fisher may set bottom longlines to take fish, aquatic life, or seaweed between the hours of 0.5 hours before nautical dawn and 0.5 hours after nautical dusk, unless line weighting is employed in accordance with clause 8 of this notice.

8. Line weighting—(1) For the purposes of clause 7, lines must be:

- (a) an integrated weighted line with a lead core of at least 50g/m; or
- (b) when externally weighted gear is used and the hook-bearing line is 3.5 millimetres or greater in diameter, every 60 metres of hook-bearing line must have at least 4 kilograms of metal weight or 5 kilograms of non-metal weight attached; or
- (c) when externally weighted gear is used and the hook-bearing line is less than 3.5 millimetres in diameter, every 60 metres of hook-bearing line must have at least 0.7 kilogram of weight attached.

(2) Regardless of the type of line weighting used under clause 8(1):

- (a) any rope or line used to attach weights to the hook-bearing line must not be longer than 20 metres; and
- (b) no more than 3 floats (up to 150 millimetres in diameter) may be attached to the hook-bearing line for every 60 metres of line, unless an additional 1 kilogram weight is added to the line per additional float; and
- (c) floats greater than 150 millimetres in diameter are not permitted to be attached to the hook bearing line.
- (d) When a separate rope or line is not used to attach a marker buoy to the hook-bearing line, and a marker buoy is attached directly, no hooks may be attached to the line within 30 metres on either side of the marker buoy.

9. Restriction of offal or fish discharge while setting and hauling bottom longlines—(1) No person may discharge offal or fish during setting of bottom longlines.

(2) Offal or fish may be discharged during the hauling of bottom longlines provided it is discharged from the side of the vessel that is opposite to the side on which the hauling station is located.

(3) Subclause (1) does not apply to:

- (a) fish that are legally undersize; or
- (b) fish that are listed on the Sixth Schedule of the Fisheries Act 1996 and that are likely to survive.

10. Revocation—The Fisheries (Seabird Sustainability Measures—Bottom Longlines) Notice 2008 (No. F430)* is revoked.

11. The Schedule—(1) The Schedule provides further guidelines on the design and deployment of streamer lines as seabird scaring devices.

(2) The Schedule is not part of the specifications.

(3) If there is any inconsistency between the guidelines in the Schedule and the specifications, the specifications prevail.

Seabird Scaring Device (Streamer line)

Diagram not to scale

Not all specifications illustrated

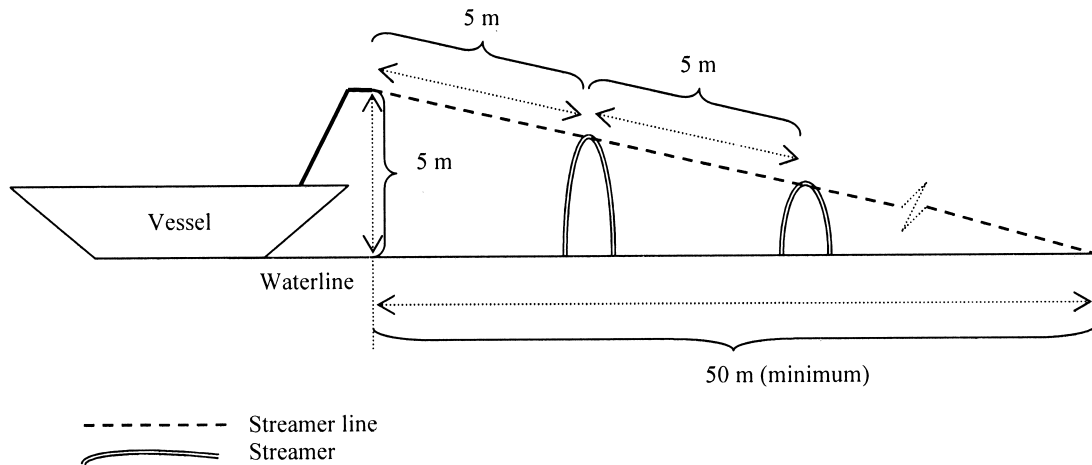

- (i) The streamer line needs to protect baited hooks from seabirds. This means that the streamer line should be positioned in such a way that streamers are flapping in an unpredictable fashion, above the area in which the baited hooks enter the sea, so that seabirds are deterred from attempting to take bait from the hooks. In order to achieve this even during cross-winds, it is expected fishers will have to make adjustments to the configuration of the streamer line depending on the conditions.
- (ii) It is generally recognised as best practice to maximise the aerial extent of the streamer line, because this maximises the area in which the baited hooks are protected from seabirds. Best practice would be to achieve an aerial extent of 100 metres or more. In order to maximise aerial extent, it is necessary to create tension in the streamer line. This can be achieved by:
 - towing an object on the terminal end of the streamer line; or
 - towing extra length of streamer line; or
 - increasing the diameter of the in-water section of the streamer line.
- (iii) In order to be effective at scaring seabirds away from the line of baited hooks, the streamer lines should not become tangled, either with each other or with the branchline. Each streamer shall be attached to the streamer line in a manner to prevent fouling of individual streamers with the streamer line, and to ensure individual streamers reach the waterline in the absence of wind or swell. Swivels or a similar device can be placed in the streamer line in such a way as to prevent streamers being twisted around the streamer line. Each streamer may also have a swivel or other device at its attachment point to the streamer line to prevent fouling of individual streamers.
- (iv) Streamers are to be spaced at 5-metre intervals along the aerial extent of the line. The total number of streamers in use will vary depending on how the line is configured. Streamers that are hanging in the water can be prone to tangling. Because the far end of the streamer line will frequently be in the water, fishers may not wish to have streamers the whole way down the line. However, it is important that streamers are present to deter birds from taking baited hooks all along the part of the line that remains above water, as outlined in the specifications.
- (v) To ensure streamers are visible to birds, they should stand out against the surroundings. Streamers should be made of brightly coloured fluorescent plastic tubing or other material. Bright colours such as red, yellow, orange or pink are most effective during day setting. For night setting, the streamers should be of a colour that contrasts with the surroundings. Colours such as blue and green are less likely to be effective, because they are less likely to be highly visible to birds.
- (vi) A complete additional streamer line should be carried as a spare.
- (vii) When externally weighted gear is used, it is not necessary for all the weight specified to be applied at 60-metre intervals along the hook-bearing line. It is equally permissible for multiple weights of smaller sizes to be attached to the hook-bearing line at shorter intervals, as long as the total weight attached along every 60 metres of hook-bearing line meets the requirement. For example, under clause 8(1)(a) of this notice, 4 kilograms of metal weight is required for every 60 metres of line. It is permissible to attach the following combinations, or any other variation that totals 4 kilograms:
 - one 4 kilogram metal weight every 60 metres along the hook bearing line; or
 - one 2 kilogram metal weight every 30 metres along the hook bearing line; or
 - one 1 kilogram metal weight every 15 metres along the hook-bearing line.

Dated at Wellington this 20th day of March 2008.

HON JIM ANDERTON, Minister of Fisheries.

*New Zealand Gazette, 21 February 2008, No. 31, page 712

go2100

Health

Medicines Act 1981

Consent to the Distribution of a Changed Medicine

Pursuant to section 20 of the Medicines Act 1981, the Minister of Health hereby consents to the distribution in New Zealand of the changed medicine which was referred to the Minister of Health under the provisions of section 24(5) of the Act and is set out in the Schedule hereto:

Schedule

<i>Product:</i>	Viread
<i>Active Ingredient:</i>	Tenofovir disoproxil fumarate 300mg
<i>Dosage Form:</i>	Film coated tablet
<i>New Zealand Sponsor:</i>	Gilead Sciences (NZ) Limited
<i>Manufacturers:</i>	Nycomed Oranienburg GmbH, Oranienburg, Germany Patheon Inc, Mississauga, Ontario, Canada Patheon Inc, Whitby Operations, Whitby, Ontario, Canada

Dated this 28th day of March 2008.

JOHN HAZELDINE, Acting Deputy Director-General, Sector Accountability and Funding Directorate (pursuant to delegation given by the Minister of Health on 6 July 2001).

go2201

Internal Affairs

Civil Union Act 2004

Civil Union Celebrants for 2008 Notice No. 6

Pursuant to the provisions of sections 26 and 27 of the Civil Union Act 2004, the following persons have been appointed as civil union celebrants for the period 3 April 2008 to 31 January 2009:

Roberts, Judie Anne, 18 Harlech Glen, Bethlehem, Tauranga.

Watson, Christine Ellen, 6 Rakau Views, Orewa, Hibiscus Coast.

Dated at Wellington this 3rd day of April 2008.

B. E. CLARKE, Registrar-General.

go2192

Marriage Act 1955

Marriage Celebrants for 2008 Notice No. 29

Pursuant to the provisions of section 11 of the Marriage Act 1955, the following names of marriage celebrants within the meaning of the said Act are published for general information:

Rennie, Gavin John, Apartment 1V, Domain Terraces, 1 George Street, Newmarket, Auckland.

Sharpe, Monica Dale, 16 Lake Road, Glenorchy.

Tahana, Gwendolynne Elizabeth, 4 Tawanui Road, Kaikohe, Northland.

Dated at Wellington this 3rd day of April 2008.

B. E. CLARKE, Registrar-General.

go2193

Marriage Celebrants for 2008 Notice No. 30

Pursuant to the provisions of section 8 of the Marriage Act 1955, the following names of marriage celebrants within the meaning of the said Act are published for general information:

Anderson, David William, Presbyterian Church of Aotearoa NZ.

Anderson, Duane Elijah, Church of Jesus Christ of Latter-Day Saints.

Anslow, Adrian Paul, Greenlane Christian Fellowship.

Arthur, Te Rawhiti Ihakara, Church of Jesus Christ of Latter-Day Saints.

Bassett, Edward Kenneth, Greenlane Christian Fellowship.

Brown, David William, Greenlane Christian Fellowship.

Calkin, Ross Terence, Greenlane Christian Fellowship.

Chase, Allan Neil, Church of Jesus Christ of Latter-Day Saints.

Grant, Ian Montgomery, Greenlane Christian Fellowship.

Greening, Simon Erick, Greenlane Christian Fellowship.

Harris, Victor Anzac Dean, Church of Jesus Christ of Latter-Day Saints.

Heilmann, Craig, Greenlane Christian Fellowship.

Henderson, William Aland, Greenlane Christian Fellowship.

Judd, Raymond Bruce, Greenlane Christian Fellowship.

Kapene, Morehu Maurice, Ratana Established Church of New Zealand.

Kirkpatrick, John William, Greenlane Christian Fellowship.

Krum, Brian Keith, Baptist.

McIntosh, Jennifer Jane, Baptist.

Parker, Allan Alfred, Greenlane Christian Fellowship.

Pauga, Lonitali, Church of Jesus Christ of Latter-Day Saints.

Porteous, Michael James, Greenlane Christian Fellowship.

Tavelia, Meletuione, Presbyterian Church of Aotearoa NZ.

White, Graham John, Greenlane Christian Fellowship.
 Wright, Francis Wilfred, Anglican.
 Wright, Kamu, Samoan Methodist Church of New Zealand.
 Yang, Stephen, Christian Missionary Alliance of Auckland.
 Young, Alistair, Presbyterian Church of Aotearoa NZ.
 Young, Bernard, Presbyterian Church of Aotearoa NZ.
 Young, Matthew Kim-Hyun, Roman Catholic.
 Zaia, Paul Augustine, Assemblies of God in New Zealand.
 Ziersch, Peter, Lutheran Church of New Zealand.

Dated at Wellington this 3rd day of April 2008.

B. E. CLARKE, Registrar-General.

go2194

Marriage Celebrants for 2008 Notice No. 31

Pursuant to the provisions of section 10 of the Marriage Act 1955, the following names of marriage celebrants within the meaning of the said Act are published for general information:

Ballara, Niccolo Francesco, City Church Wellington.
 DeLuca, Robert Daniel, His Way Church International.
 Duffy, Maurice Brett, Mountain View Christian Life Centre.
 Hellewell, Neil William, Metropolitan Community Church in Christchurch.
 Lal, Sheila, Universal Strengths.
 Marambakuyana, Cathline, Forward in Faith Ministries International.
 Omundsen, John Edward, Hawera Christian Fellowship.
 Pratt, Judah, Auckland Christian Assembly.
 Read, Phillip Brian, Brethren.
 Schollitt, Paul, House of Prayer.
 Watts, Allan Raymond, Faith Outreach Ministries.
 Wright, Ian, Brethren.

Dated at Wellington this 3rd day of April 2008.

B. E. CLARKE, Registrar-General.

go2195

Marriage Celebrants for 2008 Notice No. 32

Pursuant to the provisions of section 13 of the Marriage Act 1955, it is hereby notified that the following name will be removed from the list of marriage celebrants under section 11 of the Act as at 17 April 2008:

Rennie, Gavin John, 55 Maungakiekie Avenue, Greenlane, Auckland.

Dated at Wellington this 3rd day of April 2008.

B. E. CLARKE, Registrar-General.

go2196

Marriage Celebrants for 2008 Notice No. 33

Pursuant to the provisions of section 13 of the Marriage Act 1955, it is hereby notified that the following names will be removed from the list of marriage celebrants under sections 8 and 10 of the Act as at 17 April 2008:

Craddock, Peter Lawson, Grace City Church.
 Davis, Robert Carlyle, Brethren.

Faonelua, Mulinu'u, Church of Jesus Christ of Latter-Day Saints.

James, Mark Kim, Jehovah's Witnesses.

Papasin, Ramon Famera, Church of Jesus Christ of Latter-Day Saints.

Pokoina, Mike, Church of Jesus Christ of Latter-Day Saints.

Rush, Brent David, Church of Jesus Christ of Latter-Day Saints.

Wright, Douglas Graham, Baptist.

Wright, Kerry Robert, The Gospel Faith Messenger Ministry Inc.

Wright, Wilbur Shepherd, Greenlane Christian Fellowship.

Yancey, Troy Patrick, Church of Jesus Christ of Latter-Day Saints.

Yoon, Kun Shik, Seventh Day Adventist.

Yule, George Morrison, Presbyterian Church of Aotearoa NZ.

Yung, Jacob, Anglican.

Zhao, Christina, New Life Churches of New Zealand.

Zuidema, John, Reformed Churches of New Zealand.

Dated at Wellington this 3rd day of April 2008.

B. E. CLARKE, Registrar-General.

go2197

Justice

Justices of the Peace Act 1957

Justices of the Peace (Retired)

It is noted for information that, pursuant to section 3C(2) of the Justices of the Peace Act 1957, I have authorised the following persons to have the designation Justice of the Peace ("J.P.") (retired):

Pauline Julie Ward, of Whangarei.
 Joan Frances Cuttriss, of Wellington.
 Arnold John Buchanan, of Waitoa.
 Alexander Alan Twaddle, of Tauranga.
 Stanley Paul Keyse, of Queenstown.
 Brian Warren Gaukrodger, of Dargaville.
 George James Muir, of Te Puke.
 Vernon Antonio Avery, of Auckland.
 Roselene Frances Pola Van de Ven, of Napier.
 Robert Louis Blackwood, of Kawhia.
 Peggy Eleanor Mary Phillips, of Auckland.
 Alan William Salt, of Tauranga.
 William Brown Hamilton, of Te Aroha.
 John Roland Greenwood, of Tauranga.
 Ernest Cheriton, of Waikanae.
 Neal McGregor Crampton, of Nelson.

Dated at Wellington this 1st day of April 2008.

BELINDA CLARK, Secretary for Justice.

go2227

Sentencing Act 2002

Order for Confiscation of Motor Vehicle

Pursuant to sections 128 and 129 of the Sentencing Act 2002, an order was made in the Hawera District Court on 18 March 2008, for the confiscation of the following motor vehicle:

1992 BMW 318i, Registration No. BPW710.

Against: **Patrick Hanley O'Halloran.**

Anyone who has a legal interest in this vehicle should contact the Court urgently (telephone (06) 278 2080) as the Registrar may sell the vehicle.

This notice is placed pursuant to the Sentencing Regulations 2002.

KYLE FINDERUP, Deputy Registrar.

go2116

Order for Confiscation of Motor Vehicle

Pursuant to sections 128 and 129 of the Sentencing Act 2002, an order was made in the Christchurch District Court on 17 March 2008, for the confiscation of the following motor vehicle:

1988 Holden Vacationer, Registration No. OB4159.

Against: **Rhys David Palmer.**

Anyone who has a legal interest in this vehicle should contact the Court urgently (telephone (03) 962 4438) as the Registrar may sell the vehicle.

This notice is placed pursuant to the Sentencing Regulations 2002.

PETER FROST, Deputy Registrar.

go2211

Orders for Confiscation of Motor Vehicles

Pursuant to sections 128 and 129 of the Sentencing Act 2002, orders were made in the Christchurch District Court on 19 March 2008, for the confiscation of the following motor vehicles:

1993 Isuzu Big Horn, Registration No. BZR606.

Against: **William Frederick Baker.**

1994 Mazda MPV, Registration No. ZD9420.

Against: **Hyo Ki Jung.**

Anyone who has a legal interest in these vehicles should contact the Court urgently (telephone (03) 962 4438) as the Registrar may sell the vehicles.

This notice is placed pursuant to the Sentencing Regulations 2002.

PETER FROST, Deputy Registrar.

go2212

Orders for Confiscation of Motor Vehicles

Pursuant to sections 128 and 129 of the Sentencing Act 2002, orders were made in the Christchurch District Court on 20 March 2008, for the confiscation of the following motor vehicles:

1983 Toyota Townace, Registration No. RQ4062.

Against: **Sean Edward Laphorne.**

1996 Holden VS Commodore, Registration No. UQ9675.

Against: **Joann Mortensen.**

Anyone who has a legal interest in these vehicles should contact the Court urgently (telephone (03) 962 4438) as the Registrar may sell the vehicles.

This notice is placed pursuant to the Sentencing Regulations 2002.

PETER FROST, Deputy Registrar.

go2213

Order for Confiscation of Motor Vehicle

Pursuant to sections 128 and 129 of the Sentencing Act 2002, an order was made in the Tauranga District Court on 18 March 2008, for the confiscation of the following motor vehicle:

2007 Suzuki GSX-R1000 motorcycle, Registration No. 57ZBN.

Against: **Grant William Sellars.**

Anyone who has a legal interest in this vehicle should contact the Court urgently (telephone (07) 928 7200) as the Registrar may sell the vehicle.

This notice is placed pursuant to the Sentencing Regulations 2002.

F. O'DWYER, Deputy Registrar.

go2029

Orders for Confiscation of Motor Vehicles

Pursuant to sections 128 and 129 of the Sentencing Act 2002, orders were made in the Tauranga District Court on 27 March 2008, for the confiscation of the following motor vehicles:

1987 Honda Civic, Registration No. CTJ794.

Against: **Clare Rita O'Donnell.**

1997 Mitsubishi Galant, Registration No. DPJ568.

Against: **James William Gudsell.**

1997 Mitsubishi Galant, Registration No. DML996.

Against: **Jared Lawrence Goring.**

Anyone who has a legal interest in these vehicles should contact the Court urgently (telephone (07) 928 7200) as the Registrar may sell the vehicles.

This notice is placed pursuant to the Sentencing Regulations 2002.

F. O'DWYER, Deputy Registrar.

go2115

Order for Confiscation of Motor Vehicle

Pursuant to sections 128 and 129 of the Sentencing Act 2002, an order was made in the Wellington District Court on 26 March 2008, for the confiscation of the following motor vehicle:

1997 Toyota Levin, Registration No. DYD44.

Against: **Hinepare Diana Hakiwai.**

Anyone who has a legal interest in this vehicle should contact the Court urgently (telephone (04) 918 8482) as the Registrar may sell the vehicle.

This notice is placed pursuant to the Sentencing Regulations 2002.

SARAH MACFARLANE, Deputy Registrar.

go2186

Order for Confiscation of Motor Vehicle

Pursuant to sections 128 and 129 of the Sentencing Act 2002, an order was made in the Thames District Court on 7 March 2008, for the confiscation of the following motor vehicle:

1991 Toyota Hilux, Registration No. ARH357.

Against: **Michael Panitaua Toma.**

Anyone who has a legal interest in this vehicle should contact the Court urgently (telephone (07) 868 0061) as the Registrar may sell the vehicle.

This notice is placed pursuant to the Sentencing Regulations 2002.

JOANNE NEARY, Deputy Registrar.

go2137

Order for Confiscation of Motor Vehicle

Pursuant to sections 128 and 129 of the Sentencing Act 2002, an order was made in the Pukekohe District Court on 26 March 2008, for the confiscation of the following motor vehicle:

1989 Toyota Corolla, Registration No. OL5050.

Against: Jesse William Wilson.

Anyone who has a legal interest in this vehicle should contact the Court urgently (telephone (09) 237 0150) as the Registrar may sell the vehicle.

This notice is placed pursuant to the Sentencing Regulations 2002.

JANE HANCOCK, Court Manager.

go2118

New Zealand Food Safety Authority

Animal Products Act 1999

Notice Under the Animal Products Act 1999 (Notice No. 48)

Pursuant to section 164 of the Animal Products Act 1999, notice is given of the issue on 26 March 2008 of the Animal Products (Dairy Based Formulated Supplementary Foods – Food Standards Exemption) Notice 2008, which came into force on 26 March 2008.

Copies of the notice may be inspected or obtained at the office of the New Zealand Food Safety Authority, South Tower, 68–86 Jervois Quay (PO Box 2835), Wellington.

It can also be viewed on the NZFSA website

www.nzfsa.govt.nz

Dated this 1st day of April 2008.

CAROL BARNAO, Director (Standards), New Zealand Food Safety Authority (acting under to delegated authority).

go2237

Food Act 1981

Food Standards Under the Food Act 1981 (Notice No. 53)

Pursuant to section 11G of the Food Act 1981, notice is given that the New Zealand (Maximum Residue Limits of Agricultural Compounds) Food Standards 2008 was issued by the Minister for Food Safety on 25 March 2008 and comes into force 28 days following publication of this notice in the *New Zealand Gazette*.

Copies of the notice may be inspected or obtained at the office of the New Zealand Food Safety Authority, South Tower, 68–86 Jervois Quay (PO Box 2835), Wellington.

It can also be viewed on the NZFSA website

www.nzfsa.govt.nz

Dated this 1st day of April 2008.

CAROLE INKSTER, Director (Policy), New Zealand Food Safety Authority (acting under delegated authority).

go2238

Authorities and Other Agencies of State Notices

Environmental Risk Management Authority

Hazardous Substances and New Organisms Act 1996

Notice of Approval of Code of Practice

Pursuant to section 79(5) of the Hazardous Substances and New Organisms Act 1996, the Environmental Risk Management Authority advises that it has approved on 26 March 2008, the Code of Practice for Above Ground Tanks with Integral Secondary Containment.

This code is intended to provide a means of compliance with the regulatory requirements of Schedule 9 clause 3 of the Hazardous Substances (Dangerous Goods and Scheduled Toxic Substances) Transfer Notice 2004 (as amended) in respect of stationary tanks that have a secondary containment system that envelopes the tank (commonly known as double skin tanks).

This code can be inspected at the Wellington office of ERMA New Zealand (Level 1, BP House, 20 Customhouse Quay, Wellington), or can be downloaded from the ERMA New Zealand website

<http://www.ermanz.govt.nz>

ROB FORLONG, Chief Executive, ERMA New Zealand.

au2153

Land Transport New Zealand

Land Transport Rule: Traffic Control Devices 2004

Pedestrian Crossing Warning Lights Trial Further Extension

Pursuant to subclause 3.4(11) of the Land Transport Rule: Traffic Control Devices 2004, and pursuant to a sub-delegation to me by the Director of Land Transport, I, Lyndon Bryan Hammond, Manager Networks, hereby authorise the further continuation beyond Friday, 4 April 2008* of the installation and maintenance of experimental warning lights at three pedestrian crossings as described in the notice entitled Pedestrian Crossing Warning Lights Trial† until either this Rule is amended to allow their use or a decision is made not to so amend this Rule.

Dated at Wellington this 31st day of March 2008.

LYNDON BRYAN HAMMOND, Manager Networks.

**New Zealand Gazette*, 6 March 2008, No. 54, page 1530

†*New Zealand Gazette*, 19 January 2006, No. 5, page 104

au2187

Securities Commission

Securities Markets Act 1988

The Authorised Futures Dealers Notice 2008

Pursuant to section 38 of the Securities Markets Act 1988, the Securities Commission gives the following notice.

Notice

Clause 1: Title, commencement and expiry—(1) This notice is the Authorised Futures Dealers Notice 2008.

(2) This notice comes into force on the day after the date of its publication in the *New Zealand Gazette*.

(3) This notice expires on the close of 31 March 2013.

Clause 2: Interpretation—(1) In this notice, unless the context otherwise requires:

“Act” means the Securities Markets Act 1988.

“AFS Licence” means an Australian financial services licence granted under the Corporations Act 2001.

“ASIC” means the Australian Securities and Investments Commission.

“Commission” means the Securities Commission.

“company” means HiFX Limited.

“Corporations Act 2001” means the Corporations Act 2001 of the Commonwealth of Australia.

“product disclosure statement” means a document:

- (a) that describes and contains the offer of, and relates specifically to, the specified futures contracts;
- (b) that is identical to a document that is:
 - (i) a product disclosure statement in terms of the Corporations Act 2001; and
 - (ii) signed by the persons (if any) who are required by law to sign that document;
- (c) by means of which it is lawful under the laws of Australia to make an offer of the specified futures contracts to the public in Australia; and
- (d) that is not an “offer information statement” or “profile statement” (as those terms are defined in section 9 of the Corporations Act 2001).

“Regulations” means the Futures Industry (Client Funds) Regulations 1990.

“specified futures contract” means a futures contract that is a forward foreign exchange contract, that is issued by the company and described in the product disclosure statement.

(2) Any term or expression that is defined in the Act or the Regulations and used, but not defined, in this notice has the same meaning as in the Act or the Regulations.

Clause 3: Retail and Wholesale Client Authorisation—

(1) The company is authorised to carry on the business of dealing in specified futures contracts to which the company is, or intends to be, a party.

(2) The authorisation in this clause 3 is subject to the conditions that:

- (a) the company does not enter into specified futures contracts with any person other than a person who has entered into a written agreement with the company, and then only in accordance with the terms of that agreement;
- (b) the company is licensed as an Australian Financial Services Licensee under the Corporations Act 2001 and holds an AFS Licence which authorises the company to advise retail and wholesale clients on,

and deal with or on behalf of retail and wholesale clients in, specified futures contracts;

- (c) there is a product disclosure statement relating to the specified futures contracts at the time that the specified futures contracts are made available to New Zealand investors or the company gives advice or assistance to, or induces or attempts to induce, New Zealand investors in relation to the acquisition or disposal of any specified futures contract;
- (d) before the company enters into a specified futures contract with any person, that person has received copies of the following:
 - (i) A product disclosure statement relating to that specified futures contract; and
 - (ii) every supplementary product disclosure statement relating to that specified futures contract in use at the time of the entry by the company into the specified futures contract;
- (e) the company must hold client funds in a segregated client funds account as if the funds were subject to the provisions of its AFS licence, the Corporations Act 2001 and any regulations made under the Corporations Act 2001 in relation to the protection of client money and client property;
- (f) the company maintains proper records:
 - (i) to record dealings in respect of specified futures contracts with clients;
 - (ii) to record client money, funds and property held or received in connection with dealings in specified futures contracts; and
 - (iii) which are audited or reviewed, and reported on, in accordance with the company’s AFS Licence;
- (g) the company maintains adequate professional indemnity insurance for its business at all times;
- (h) the company maintains at all times an external dispute resolution scheme that is available to its New Zealand clients who are members of the public; and
- (i) at the same time as the specified futures contracts are made available by the company to New Zealand investors in reliance on the authorisation in this notice, those specified futures contracts are also made available to Australian investors in accordance with the laws of Australia.

Clause 4: Wholesale Client Advisory Authorisation—

(1) The company is authorised to carry on the business of dealing in futures contracts that consists of advising or assisting a person in connection with the acquisition or disposal of futures contracts that are forward foreign exchange contracts to which the company is not, and does not intend to be, a party.

(2) The authorisation in this clause 4 is subject to the conditions that:

- (a) the company does not hold client money or client property in connection with such dealings in futures contracts; and
- (b) the company does not carry on the business of dealing in such futures contracts on behalf of any person other than a person who has entered into a written agreement with the company, and then only in accordance with the terms of that agreement; and
- (c) the company deals in such futures contracts only on behalf of its wholesale clients, being any client that is:
 - (i) a person who controls at least \$10 million; or

- (ii) a trustee of a trust or a funds manager, acting in that capacity, who has under that person's control, as trustee or funds manager, net assets of at least \$10 million; or
 - (iii) a person who is authorised to carry on the business of dealing in futures contracts under the Act; or
 - (iv) a person authorised in another jurisdiction by the competent authority of that jurisdiction to deal in futures contracts; or
 - (v) Her Majesty The Queen in right of New Zealand, a Crown entity named in the Crown Entities Act 2004, or a State enterprise named in the First or Second Schedule of the State-Owned Enterprises Act 1986 (each as amended from time to time); or
 - (vi) a person who is a statutory corporation or a registered bank; or
 - (vii) a person whose principal business is the investment of money or who, in the course of and for the purposes of their business, habitually invests money; or
 - (viii) a person who is a related body corporate of any of the persons mentioned in (i) to (vii) above; and
- (d) before dealing in any futures contract in respect of which the authorisation in this clause 4 applies, the company is satisfied on reasonable grounds that the wholesale client is contracting:
- (i) as principal on its own account; or
 - (ii) on behalf of a related body corporate; or
 - (iii) as trustee of a trust or manager of a managed fund; and
- (e) the terms of any such futures contract:
- (i) create obligations that cannot be transferred or terminated by either party to the futures contract without the consent of the other party; or
 - (ii) require that the transfer of obligations under the futures contract can be made only to a person who meets the criteria described in subclauses 4(2)(c) and (d).
- Commission of any regulatory action taken by ASIC in relation to the company's AFS Licence; and
- (b) provides the Commission with a copy of the company's audited financial statements no later than three months after the end of each financial year for the company; and
 - (c) any company document that states the company has been authorised by the Commission to carry on the business of dealing in futures contracts includes a statement to the effect that:
 - (i) the Commission's role in authorising futures dealers is limited and does not imply approval or endorsement of the business, trading or solvency of the company; and
 - (ii) the Commission has not approved any agreements or any disclosure documents of the company; and
 - (d) the company immediately notifies the Commission in writing of any of the following events:
 - (i) the insolvency of the company or the bankruptcy of any of its directors or senior management;
 - (ii) if the company, or any of its directors or senior management, is convicted of an indictable offence;
 - (iii) where a receiver, provisional liquidator, liquidator or a similar officer is appointed, or any resolution is passed or order made for the winding up or dissolution of the company;
 - (iv) any regulatory action taken against the company, or any of its directors or senior management whether in New Zealand or elsewhere;
 - (v) if any director or member of the senior management leaves the company or if any new director or member of senior management is appointed to the company; and
 - (vi) if any auditor's report prepared in accordance with the company's AFS Licence shows any non-compliance with the company's AFS Licence or the Corporations Act 2001.

Dated at Wellington this 2nd day of April 2008.

The Common Seal of the Securities Commission was affixed in the presence of:

[L.S.]

JANE DIPLOCK, Chairperson.

au2239

Land Notices

Conservation Act 1987

Declaring Land to be Held for Conservation Purposes and Declaration That the Area be Part of the Petane War Memorial Reserve

Under the Conservation Act 1987, the Conservator of the East Coast Hawke's Bay Conservancy of the Department of Conservation declares that the land described in the Schedule is held for conservation purposes and further declares that the conservation area is set apart as a reserve, subject to the Reserves Act 1977, and classified as a recreation reserve, subject to the provisions of the latter Act,

and further declares the recreation reserve described in the Schedule form part of the Petane War Memorial Reserve.

Hawke's Bay Land District—Napier District Schedule

Area m ²	Description
------------------------	-------------

1922	Section 15 Block XVI Puketapu Survey District.
------	--

Dated at Gisborne this 31st day of March 2008.

P. J. WILLIAMSON.

(DOC PAR-08-02-19)

In2191

Public Works Act 1981

Road Realignment—Kerikeri Bypass, Kerikeri

Pursuant to the Public Works Act 1981, and to a delegation from the Minister for Land Information, Stephen Robert Gilbert, Land Information New Zealand:

(a) Pursuant to section 20, declares that, an agreement to that effect having been entered into, the land described in the First Schedule to this notice is hereby acquired for road, the land described in the Second Schedule is hereby acquired for segregation strip, the land described in the Third Schedule is hereby acquired in connection with a road, and all the above is vested in the Far North District Council on the date of publication of this notice in the *New Zealand Gazette*.

(b) Pursuant to section 119, declares the land described in the Fourth Schedule to this notice is hereby taken for severance and vested in the Far North District Council on the date of publication of this notice in the *New Zealand Gazette*.

North Auckland Land District—Far North District

First Schedule

Land Acquired for Road

Area ha	Description
3.1135	Part Lot 2 DP 33905 and part Lot 6 DP 33905; shown as Section 4 on SO 397462 (part Computer Freehold Register NA55B/1036).

Second Schedule

Land Acquired for Segregation Strip

Area m ²	Description
106	Part Lot 2 DP 33905; shown as Section 2 on SO 397462 (part Computer Freehold Register NA55B/1036).
138	Part Lot 2 DP 33905 and part Lot 6 DP 33905; shown as Section 8 on SO 397462 (part Computer Freehold Register NA55B/1036).
55	Part Lot 2 DP 33905 and part Lot 6 DP 33905; shown as Section 11 on SO 397462 (part Computer Freehold Register NA55B/1036).

Third Schedule

Land Acquired in Connection With a Road

Area m ²	Description
843	Part Lot 2 DP 33905; shown as Section 1 on SO 397462 (part Computer Freehold Register NA55B/1036).
ha	
1.1096	Part Lot 2 DP 33905; shown as Section 6 on SO 397462 (part Computer Freehold Register NA55B/1036).

Fourth Schedule

Land Acquired for Severance

Area m ²	Description
9112	Part Lot 2 DP 33905; shown as Section 3 on SO 397462 (part Computer Freehold Register NA55B/1036).

Dated at Christchurch this 18th day of March 2008.
S. R. GILBERT, for the Minister for Land Information.
(LINZ CPC/2005/10885)

In2097

Road Realignment—Davies Road, New Plymouth District

Pursuant to the Public Works Act 1981, and to a delegation from the Minister for Land Information, Stephen Robert Gilbert, Land Information New Zealand:

(a) Pursuant to section 114, declares the land described in the First Schedule to this notice to be road and shall vest in the New Plymouth District Council;

(b) Pursuant to sections 116 and 117, declares the portion of road adjoining or passing through the land described in the Second Schedule to this notice is to be stopped and, pursuant to section 120(3), amalgamated with the land in Computer Freehold Register 188107

on the date of publication of this notice in the *New Zealand Gazette*.

Taranaki Land District—New Plymouth District Council First Schedule

Land Declared Road

Area m ²	Description
516	Part Lot 1 DP 13196; shown as Section 2 on SO 375881 (part Computer Freehold Register 188107).

Second Schedule

Road Stopped and Amalgamated

Area m ²	Description
383	Part Lot 21 DP 342803 and part Lot 1 DP 13196 (Computer Freehold Register 188107); shown as Section 1 on SO 375881.

Dated at Christchurch this 25th day of March 2008.
S. R. GILBERT, for the Minister for Land Information.
(LINZ CPC/2005/10762)

In2131

Land Set Apart for Education Purposes—Ohakune Primary School, Ohakune

Pursuant to section 52(1) of the Public Works Act 1981, and to a delegation from the Minister for Land Information, Stephen Robert Gilbert, Land Information New Zealand, declares the land described in the Schedule to this notice is to be set apart for education purposes and shall remain vested in the Crown on the date of publication of this notice in the *New Zealand Gazette*.

Wellington Land District—Ruapehu District Council Schedule

Land Set Apart for Education Purposes

Area ha	Description
4.0469	Section 37 Ohakune Village Settlement (all Computer Freehold Register WN499/247).

Dated at Christchurch this 18th day of March 2008.
S. R. GILBERT, for the Minister for Land Information.
(LINZ CPC/2008/12641)

In2103

Road Stopped—Riro Street, Hamilton City

Pursuant to section 116(1) of the Public Works Act 1981, and to a delegation from the Minister for Land Information, Stephen Robert Gilbert, Land Information New Zealand, declares the portion of road described in the Schedule to this notice to be stopped and to remain vested in the Hamilton City Council.

South Auckland Land District—Hamilton City**Schedule***Road to be Stopped*

Area m ²	Description
40	Adjoining or passing through Lot 36 DP 5171 (Computer Freehold Register 153386); shown as Section 1 on SO 392026.

Dated at Christchurch this 12th day of March 2008.

S. R. GILBERT, for the Minister for Land Information.

(LINZ CPC/2006/11285)

ln2232

Land Set Apart for the Generation of Electricity—Arapuni Power Station, Waipa District

Pursuant to section 52(1) of the Public Works Act 1981, and to a delegation from the Minister for Land Information, Stephen Robert Gilbert, Land Information New Zealand, declares the land described in the Schedule to this notice to be set apart for the generation of electricity and shall remain vested in the Crown.

South Auckland Land District—Waipa District**Schedule**

Area m ²	Description
8632	Crown land reserved from sale – pursuant to section 58 of the Land Act 1948; shown as Section 1 on SO 384548.

Dated at Christchurch this 18th day of March 2008.

S. R. GILBERT, for the Minister for Land Information.

(LINZ CPC/2007/12100)

ln2102

Land Declared Road—State Highway 1, Braigh Passing Lane, Whangarei District

Pursuant to section 114 of the Public Works Act 1981, and to a delegation from the Minister for Land Information, R. J. Sutherland, Land Information New Zealand, declares the land described in the Schedule to this notice to be road which, pursuant to section 88(2) of the Transit New Zealand Act 1989, becomes road, limited access road and State highway and shall vest in the Crown on the date of publication of this notice in the New Zealand Gazette.

North Auckland Land District—Whangarei District Council**Schedule***Land Declared Road*

Area m ²	Description
1347	Part Lot 2 DP 194000; shown as Section 3 on SO 389660 (part Computer Freehold Register NA123A/512).

Dated at Auckland this 26th day of March 2008.

R. J. SUTHERLAND, for the Minister for Land Information.

(LINZ CPC/2002/8219)

ln2130

Road Realignment—Oneriri Road, Kaiwaka

Pursuant to the Public Works Act 1981, and to a delegation from the Minister for Land Information, R. J. Sutherland, Land Information New Zealand:

(a) Pursuant to section 20, declares that, agreements to that effect having been entered into, the land described in the First Schedule to this notice is hereby acquired for road

and is vested in the Kaipara District Council on the date of publication of this notice in the *New Zealand Gazette*.

(b) Pursuant to sections 116 and 117, declares the portions of road adjoining or passing through the land described in the Second, Third, Fourth and Fifth Schedules to this notice to be stopped and, pursuant to section 120(3):

- (i) the area described in the Second Schedule amalgamated with the land in Computer Freehold Register NA99C/550, subject to mortgages 171428.5 and D375987.2.
- (ii) the area described in the Third Schedule amalgamated with the land in Computer Freehold Register NA74B/934, subject to mortgage C190367.2.
- (iii) the area described in the Fourth Schedule amalgamated with the land in Computer Freehold Register NA121D/122.
- (iv) the area described in the Fifth Schedule amalgamated with the land in Computer Freehold Register NA74B/926.

North Auckland Land District—Kaipara District**First Schedule***Land Acquired for Road*

Area m ²	Description
2873	Part Lot 2 DP 211193; shown as Section 1 on SO 342769 (part Computer Freehold Register NA139B/413).
154	Part Section 15 Block VI Otamatea Survey District; shown as Section 2 on SO 342769 (part Computer Freehold Register NA99C/550).
4042	Part Section 15 Block VI Otamatea Survey District; shown as Section 4 on SO 342769 (part Computer Freehold Register NA99C/550).
319	Part Lot 10 DP 127616; shown as Section 7 on SO 342769 (part Computer Freehold Register NA74B/934).
68	Part Section 1 SO 67736; shown as Section 9 on SO 342769 (part Computer Freehold Register NA199C/550).
27	Part Lot 1 DP 171090; shown as Section 10 on SO 342769 (part Computer Freehold Register NA97B/887).
209	Part Lot 3 DP 192003; shown as Section 11 on SO 342769 (part Computer Freehold Register NA1210/123).
100	Part Lot 3 DP 192003; shown as Section 12 on SO 342769 (part Computer Freehold Register NA1210/123).
3085	Part Lot 2 DP 171090; shown as Section 13 on SO 342769 (part Computer Freehold Register NA97B/887).

Second Schedule*Road Stopped and Amalgamated*

Area m ²	Description
756	Adjoining or passing through Section 15 Block VI Otamatea Survey District; shown as Section 3 on SO 342769.

Third Schedule*Road Stopped and Amalgamated*

Area m ²	Description
666	Adjoining or passing through Lot 10 DP 127616; shown as Section 6 on SO 342769.

- 139 Adjoining or passing through Lot 10 DP 127616; shown as Section 8 on SO 342769.

Fourth Schedule

Road Stopped and Amalgamated

Area m ²	Description
476	Adjoining or passing through Lot 2 DP 192003; shown as Section 14 on SO 342769.

Fifth Schedule

Road Stopped and Amalgamated

Area m ²	Description
842	Adjoining or passing through Lot 1 DP 127613; shown as Section 15 on SO 342769.

Dated at Auckland this 20th day of March 2008.

R. J. SUTHERLAND, for the Minister for Land Information.
(LINZ CPC/2005/10895)

ln2142

Land Acquired for Road—77 Paterson Street, Mt Maunganui

Pursuant to section 20 of the Public Works Act 1981, and to a delegation from the Minister for Land Information, R. J. Sutherland, Land Information New Zealand, declares that, an agreement to that effect having been entered into, the land described in the Schedule to this notice is hereby acquired for road and shall vest in the Tauranga City Council on the date of publication of this notice in the *New Zealand Gazette*.

South Auckland Land District—Tauranga City Council Schedule

Area m ²	Description
119	Part Lot 208 DP 35626; shown as Section 10 on SO 332244 (part Computer Freehold Register SA20B/850).

Dated at Auckland this 20th day of March 2008.

R. J. SUTHERLAND, for the Minister for Land Information.
(LINZ CPC/2005/10907)

ln2096

Land Set Apart for Local Purpose Reserve—Westminster Avenue, Napier City

Pursuant to sections 20(1) and 52 of the Public Works Act 1981, and to a delegation from the Minister for Land Information, R. J. Sutherland, Land Information New Zealand, declares that, pursuant to an agreement to that effect having been entered into, the land described in the Schedule to this notice is hereby set apart as a local purpose (drainage) reserve, subject to the Reserves Act 1977, and is vested in the Napier City Council on the date of publication of this notice in the *New Zealand Gazette*.

Hawke's Bay Land District—Napier City Schedule

Area m ²	Description
1863	Section 1 SO 11019.
732	Section 2 SO 11019.

Dated at Auckland this 6th day of June 2003.

R. J. SUTHERLAND, for the Minister for Land Information.
(LINZ CPC/2003/8995)

ln2108

Declaring Land to be Service Lane—Station Street, Napier

Pursuant to section 114(1) of the Public Works Act 1981, and to a delegation from the Minister for Land Information, R. J. Sutherland, Land Information New Zealand, declares the land described in the Schedule to this notice to be service lane and vested in the Napier City Council on the date of publication of this notice in the *New Zealand Gazette*.

Hawke's Bay Land District—Napier City Schedule

Area m ²	Description
39	Part Lot 4 DP 331; shown as Section 1 on SO 366922 (part Computer Freehold Register HBH1/1218).
7	Part Lot 5 DP 331; shown as Section 2 on SO 366922 (part Computer Freehold Register HB87/287 (Int)).
32	Part Lot 2 DP 3881; shown as Section 3 on SO 366922 (part Computer Freehold Register HB72/39).

Dated at Auckland this 27th day of March 2008.

R. J. SUTHERLAND, for the Minister for Land Information.
(LINZ CPC/2005/10900)

ln2236

Amending a Notice for Land Declared to be Road and Vested in Block V, Wai-iti Survey District—Motueka Valley Highway, Tapawera, Nelson

Pursuant to section 55 of the Public Works Act 1981, and to a delegation from the Minister for Land Information, R. J. Sutherland, Land Information New Zealand, hereby amends the notice dated the 28th day of September 1984, and published in *New Zealand Gazette*, 4 October 1984, No. 178, page 4146, by omitting the words contained in item (b) in the body of the notice and the Second Schedule of the notice and substituting the following:

“(b) Pursuant to section 119, declares the land described in the Second Schedule to this notice to be taken and amalgamated with the land in Computer Freehold Register NL8A/579, subject to mortgages 357630.4 and 357630.5.”

and

“Second Schedule

Nelson Land District—Tasman District

Area m ²	Description
1110	Section 1 SO 13128.”

Dated at Auckland this 14th day of March 2008.

R. J. SUTHERLAND, for the Minister for Land Information.
(LINZ CPC/2007/12281)

ln2095

Road Realignment—Grays Road, Amberley, Hurunui District

Pursuant to the Public Works Act 1981, and to a delegation from the Minister for Land Information, R. J. Sutherland, Land Information New Zealand:

(a) Pursuant to section 114, declares the land described in the First Schedule to this notice to be road and vested in the Hurunui District Council;

(b) Pursuant to sections 116 and 117, declares the road described in the Second, Third and Fourth Schedules to this notice to be stopped and, pursuant to section 120(3):

- (i) the area described in the Second Schedule shall be amalgamated with the land in Computer Freehold Register 15260, Canterbury Land Registry;
- (ii) the area described in the Third Schedule shall be amalgamated with the land in Computer Freehold Register CB40A/231, Canterbury Land Registry; and
- (iii) the area described in the Fourth Schedule shall revert to the bed of the North Branch Kowai River

on the date of publication of this notice in the *New Zealand Gazette*.

Canterbury Land District—Hurunui District

First Schedule

Land for Road

Area m ²	Description
2592	Section 1 SO 354645.
795	Section 3 SO 354645.

Second Schedule

Road to be Stopped

Area m ²	Description
1442	Section 2 SO 354645.

Third Schedule

Road to be Stopped

Area m ²	Description
1610	Section 4 SO 354645.

Fourth Schedule

Road to be Stopped

Area m ²	Description
272	Section 5 SO 354645.

Dated at Auckland this 19th day of March 2008.

R. J. SUTHERLAND, for the Minister for Land Information.
(LINZ CPC/2006/11288)

ln2107

Road Realignment—Lethbridge Road, Otorohanga District

Pursuant to the Public Works Act 1981, and to a delegation from the Minister for Land Information, Ronald Alistair Jolly, Land Information New Zealand:

(a) Pursuant to section 114, declares the land described in the First Schedule to this notice to be road vested in the Otorohanga District Council.

(b) Pursuant to sections 116 and 117, declares the portion of road described in the Second Schedule to this notice to be stopped and amalgamated with the land in Computer Freehold Register SA25D/471, subject to mortgage 5125768.3.

South Auckland Land District—Otorohanga District

First Schedule

Land for Road

Area m ²	Description
157	Part Lot 2 DP S22557; shown as Section 5 on SO 376015 (part Computer Freehold Register SA25D/471).
1785	Parts Lot 3 DP 20794; shown as Sections 3 and 4 on SO 376015 (parts Computer Freehold Register SA10A/1416).

Second Schedule

Road Stopped and Amalgamated

Area m ²	Description
1411	Section 2 on SO 376015.

Dated at Wellington this 7th day of March 2008.

R. A. JOLLY, for the Minister for Land Information.
(LINZ CPC/2007/12340)

ln2216

Reserves Act 1977

Corrigendum—Classification and Naming of Part of a Reserve

In the notice with the above heading dated the 12th day of March 2008 and published in the *New Zealand Gazette*, 20 March 2008, No. 63, page 1828, please replace

“67.3333”

with

“16.4577”

and

“PAP-11-09-26”

with

“PAP-11-05-05”

ln2219

Authorisation of the Exchange of Part of a Reserve for Other Land

Under the Reserves Act 1977, the Conservator of the East Coast Hawke's Bay Conservancy of the Department of Conservation authorises the exchange of that part of the local purpose reserve described in the First Schedule for the land described in the Second Schedule.

Hawke's Bay Land District—Hastings District

First Schedule

Area m ²	Description
98	Section 1 SO 388820.

Second Schedule

Area m ²	Description
118	Lot 6 DP 401191.

Dated at Gisborne this 31st day of March 2008.

P. J. WILLIAMSON.

(DOC PAL-06-08)

ln2202

Classification of Reserves

Under the Reserves Act 1977, the Acting Conservation Support Manager for the Wellington Conservancy of the Department of Conservation classifies the reserves described in the Schedule as reserves for recreation purposes, and further declares the said reserves to form part of the Whitireia Park Recreation Reserve be administered by the Whitireia Park Board.

Wellington Land District—Porirua City

Schedule

Area ha	Description
2.6036	Lot 40 DP 43619 Block XI situated in Paekakariki District Survey (part Computer Freehold Register WN24A/47).

- 0.6998 Lots 166 and 167 DP 42707 situated in Block XI Paekakariki Survey District (part Computer Freehold Register WN24A/47).
- 0.0008 Lots 26 and 27 DP 42707 situated in Block XI Paekakariki Survey District.

Dated at Wellington this 27th day of March 2008.
ANARU LUKE, Acting Conservation Support Manager.
(DOC PAR-09-02-19)

In2157

Regulation Summary

Notice Under the Acts and Regulations Publication Act 1989

Pursuant to the Acts and Regulations Publication Act 1989, notice is hereby given of the making of Regulations as under:

<i>Authority for Enactment</i>	<i>Title or Subject-matter</i>	<i>Serial Number</i>	<i>Date of Enactment</i>	<i>Retail</i>
Civil List Act 1979 and Remuneration Authority Act 1977	Civil List Determination 2008	2008/90	19/3/08	\$1.60
Civil List Act 1979 and Remuneration Authority Act 1977	Civil List (Annuities) Determination 2008	2008/91	19/3/08	\$2.10
Limited Partnerships Act 2008	Limited Partnerships Act 2008 Commencement Order 2008	2008/92	31/3/08	\$1.60
Limited Partnerships Act 2008	Limited Partnerships Regulations 2008	2008/93	31/3/08	\$2.30
Immigration Act 1987	Immigration (Transit Visas) Amendment Regulations 2008	2008/94	31/3/08	\$1.60

Postage and Packaging Charge: Mail Orders

If two or more copies are ordered, the remittance should cover the *cash price* and the *maximum charge* for the *total value of purchases* as follows:

<i>Total Value of Purchases</i>	<i>Maximum Charge</i>
\$12.00 and less	\$1.75 p&p
\$12.01 to \$30.00	\$3.50 p&p
\$30.01 and greater	\$5.50 p&p

Copies can be bought or ordered by mail from Legislation Direct, PO Box 12357, Wellington. Please quote title and serial numbers. Prices for quantities supplied on application. Copies are also available over the counter at the following locations:

Bennetts Bookshop: Bowen House, Lambton Quay (PO Box 5334), Wellington; Bennetts Campus Bookshop: Auckland University of Technology, C Block Wellesley Street, Gate 4 Lorne Street (Private Bag 92006), Auckland; University of Waikato, Gate 5 Hillcrest Road (PO Box 13066), Hamilton; Located in Whitcoulls: Centreplace, Bryce Street (PO Box 19287), Hamilton; 38–42 Broadway Avenue (PO Box 1820), Palmerston North; 111 Cashel Street (Private Bag), Christchurch; 143 George Street (PO Box 1104), Dunedin.

rs2264

General Section

The Community Trust of Southland

Community Trusts Act 1999

The Community Trust of Southland

Consolidated Statement of Financial Performance for the Year Ended 31 March 2007

	<i>Note</i>	<i>2007 Group</i>	<i>2006 Group</i>	<i>2007 Parent</i>	<i>2006 Parent</i>
Total operating revenue	1	8,330,880	38,337,802	7,671,984	37,546,414
Revaluation of land and buildings	17	135,773	96,859	135,773	96,859
		8,466,653	38,434,661	7,807,757	37,643,273
Total expenditure	2	2,325,114	2,158,737	1,989,947	1,850,807

Total operating surplus before distributions	6,141,539	36,275,924	5,817,810	35,792,466
<i>Less:</i> Distributions				
Donations to tax approved entities:				
– relating to current year	7,766,094	6,838,605	7,766,094	6,838,605
– relating to future years	4,004,000	–	4,004,000	–
	<u>11,770,094</u>	<u>6,838,605</u>	<u>11,770,094</u>	<u>6,838,605</u>
Net surplus/(deficit)	<u>(5,628,555)</u>	<u>29,437,319</u>	<u>(5,952,284)</u>	<u>28,953,861</u>
The surplus/(deficit) has been allocated to:				
Capital maintenance reserve	4,827,366	6,168,561	4,827,366	6,168,561
Grants maintenance reserve	<u>(10,455,921)</u>	<u>23,268,758</u>	<u>(10,779,650)</u>	<u>22,785,300</u>
	<u>(5,628,555)</u>	<u>29,437,319</u>	<u>(5,952,284)</u>	<u>28,953,861</u>

Consolidated Statement of Movements in Equity for the Year Ended 31 March 2007

	2007 Group	2006 Group	2007 Parent	2006 Parent
Net retained surplus/(deficit)	(5,628,555)	29,437,319	(5,952,284)	28,953,861
<i>Less:</i> Grants paid from capital	–	(631,317)	–	(631,317)
	<u>(5,628,555)</u>	<u>28,806,002</u>	<u>(5,952,284)</u>	<u>28,322,544</u>
Equity at beginning of year	<u>196,609,998</u>	<u>167,803,996</u>	<u>198,125,629</u>	<u>169,803,085</u>
Equity at the end of the year	<u>190,981,443</u>	<u>196,609,998</u>	<u>192,173,345</u>	<u>198,125,629</u>

Consolidated Statement of Financial Position as at 31 March 2007

	Note	2007 Group	2006 Group	2007 Parent	2006 Parent
Funds employed:					
Trust capital	9	158,460,000	158,460,000	158,460,000	158,460,000
Reserves	8	<u>32,521,443</u>	<u>38,149,998</u>	<u>33,713,345</u>	<u>39,665,629</u>
Total capital and reserves		<u>190,981,443</u>	<u>196,609,998</u>	<u>192,173,345</u>	<u>198,125,629</u>
Liabilities—					
Current liabilities:					
Accounts payable and accrued expenses		301,114	250,855	215,148	201,504
Grants committed but not paid		<u>9,689,194</u>	<u>9,799,098</u>	<u>9,689,194</u>	<u>9,799,098</u>
Total current liabilities		<u>9,990,308</u>	<u>10,049,953</u>	<u>9,904,342</u>	<u>10,000,602</u>
Non current liabilities:					
Grants committed but not paid	16	<u>4,004,000</u>	–	<u>4,004,000</u>	–
Total liabilities		<u>13,994,308</u>	<u>10,049,953</u>	<u>13,908,342</u>	<u>10,000,602</u>
Total capital and liabilities		<u>204,975,751</u>	<u>206,659,951</u>	<u>206,081,687</u>	<u>208,126,231</u>
Assets—					
Current assets:					
Bank and deposits		206,164	1,193,311	2,796	12,458
Accounts receivable and interest accrual	10	218,047	110,749	157,781	25,479
Other deposits		132,753	2,766	132,753	2,766
Back Country Foods Limited	11	2,995	2,995	–	–
Taxation		–	–	–	–
Trading stock		84,515	–	–	–
Goods and services taxation		19,434	11,114	–	–
Current portion of other investments		350,000	–	–	–
Current portion of loan funding	12	<u>1,212,656</u>	<u>751,038</u>	–	–
Total current assets		<u>2,226,564</u>	<u>2,071,973</u>	<u>293,330</u>	<u>40,703</u>
Non current assets:					
Property, plant and equipment	17	936,165	811,115	933,967	807,635
Managed funds:					
ING (NZ) Limited	18	36,996,072	35,461,385	36,996,072	35,461,385
Tower Asset Management	18	50,233,161	46,918,637	50,233,161	46,918,637
AMP Asset Management	18	35,150,374	29,366,863	35,150,374	29,366,863
Capital International	18	35,338,274	36,478,490	35,338,274	36,478,490
Alliance Bernstein	18	37,273,175	49,917,310	37,273,175	49,917,310
Loans	13	2,095,141	1,367,015	2,095,141	1,367,015
Loan funding	12	4,084,108	3,767,992	–	–

Investment in associates	14	517,717	149,171	–	–
Investment in subsidiary		–	–	7,768,193	7,768,193
Other investments		<u>125,000</u>	<u>350,000</u>	<u>–</u>	<u>–</u>
Total non current assets		<u>202,749,187</u>	<u>204,587,978</u>	<u>205,788,357</u>	<u>208,085,528</u>
Total assets		<u>204,975,751</u>	<u>206,659,951</u>	<u>206,081,687</u>	<u>208,126,231</u>

Consolidated Statement of Cash Flows for the Year Ended 31 March 2007

	Note	2007 Group	2006 Group	2007 Parent	2006 Parent
Cash flows from operating activities—					
Cash was provided from/(applied to):					
Receipts from customers		27,890	113,585	–	–
Interest received		3,949,616	3,132,256	3,250,020	2,526,773
Dividends received		4,981,052	6,717,084	4,957,348	6,713,001
Revaluation of investments		–	28,808,823	–	28,808,823
Taxation refund received		–	1,379	–	–
Payments to suppliers and employees		(2,311,093)	(2,077,846)	(1,916,878)	(1,794,248)
Grants to the community		(7,835,998)	(7,908,453)	(7,835,998)	(7,908,453)
Interest paid		(79)	(91)	–	–
Income taxes paid		–	(11,114)	–	–
Net cash flows from operating activities	15	<u>(1,188,612)</u>	<u>28,775,623</u>	<u>(1,545,508)</u>	<u>28,345,896</u>
Cash flows from investing activities—					
Cash was provided from/(applied to):					
Repayment of debt funding advanced		–	–	–	–
Drawdown of debt funding from recipients		(461,618)	(2,453,298)	–	–
Investments		1,919,913	(26,723,232)	2,336,030	(28,095,404)
Increase in associate investments		(375,246)	–	–	–
Purchase of property, plant and equipment		(56,799)	350,218	(56,799)	–
Proceeds on sale of property, plant and equipment		4,615	–	4,500	–
Increase in trading stock		(84,515)	–	–	–
Dividends received on investment in associates		3,000	6,000	–	–
Loan advances		(800,000)	(366,179)	(800,000)	(366,179)
Loan repayments		<u>52,115</u>	<u>–</u>	<u>52,115</u>	<u>–</u>
Net cash flows from investing activities		<u>201,465</u>	<u>(29,186,491)</u>	<u>1,535,846</u>	<u>(28,461,583)</u>
Net increase/(decrease) in cash held		(987,147)	(410,868)	(9,662)	(115,687)
Cash balances at beginning of the year		<u>1,193,311</u>	<u>1,604,179</u>	<u>12,458</u>	<u>128,145</u>
Cash balances at end of year		<u>206,164</u>	<u>1,193,311</u>	<u>2,796</u>	<u>12,458</u>

Statement of Significant Accounting Policies for the Year Ended 31 March 2007

A. Basis of Preparation

The Community Trust of Southland was formed under the Trustee Banks Restructuring Act 1988 and is incorporated under the Charitable Trusts Act 1957. The financial statements presented are those for The Community Trust of Southland (“the trust”) making up the parent. The group consists of The Community Trust of Southland (“the trust”), its wholly owned subsidiary companies Southland Community Trust Charities Limited and Invest South Limited Group.

The financial statements comply with the Financial Reporting Act 1993, the Community Trusts Act 1999 and the Companies Act 1993. They comprise statements of the following: Significant accounting policies, financial performance, movements in trust funds, financial position, cash flows, as well as notes to these statements.

The financial statements are prepared on the basis of historical cost except that investment assets are stated at valuation, as is the trust’s property at 62 Don Street, Invercargill.

B. Consolidation Method

The financial statements of the trust’s wholly owned companies are included in the financial statements of the group using the purchase method of consolidation.

C. Associates

Associates are entities in which the group has significant influence, but not control over the operating and financial policies. The financial statements include the group’s share of the net surplus of associates since acquisition on an equity accounted basis.

D. Goodwill Arising on Acquisition of Associates

Goodwill arising on the acquisition of an associate represents the excess of the purchase consideration over the fair value of the identifiable assets acquired. Goodwill is stated at cost and amortised to the statement of financial performance on a straight line basis over the period during which benefits are expected to be derived – a period not exceeding 20 years.

E. Trust Capital

Following the sale of the trust’s shares in Trust Bank New Zealand Limited in April 1996 for \$158,460,000, the trustees agreed that the value of the trust at that time should be maintained for the benefit of current and future generations living in the region. For this purpose, the trustees agreed that \$158,460,000 would be considered as the “trust capital” value of the parent. Trustees

further agreed that over the long term, the net assets of the parent would not be allowed to reduce to a level below the inflation-adjusted real value of this trust capital.

F. Capital Maintenance Reserve

The capital maintenance reserve represents the additional amount necessary to preserve the real value of the trust capital allowing for inflation as measured by the Consumers Price Index (all groups) and payments of grants out of capital.

G. Grants Maintenance Reserve

While the trustees have adopted a long-term investment strategy, they accept that annual returns from investments are likely to fluctuate from year to year. In recognition of this, a grants maintenance reserve is maintained. In years when net income from investments is higher than the grant levels, surplus income will be transferred to this reserve. In years when there is insufficient income to sustain the level of grants, an appropriate amount will be transferred from the grants maintenance reserve to income.

H. Basis of Recognising Components of the Financial Statements

The following general accounting policies are adopted:

Assets

A transaction results in an asset being recognised in the statement of financial position when it will probably give rise to ongoing benefits for the group and those benefits can be measured with reliability.

Liabilities

A transaction results in a liability being recognised in the statement of financial position when it will probably give rise to the need for the group to sacrifice assets in the future and those sacrifices can be measured with reliability.

Revenue

Revenue is recognised in the statement of financial performance when a transaction gives rise to an increase in the value of the group's net assets, and that increase can be measured with reliability.

Expenses

An expense is recognised in the statement of financial performance when a transaction results in a decrease in the value of the group's net assets, and that decrease can be measured with reliability.

Classification of Assets and Liabilities Between Current and Non-current

An amount is classified as current when it is expected to be settled or extinguished within one year of the date of the financial statements. All other amounts are classified as non-current.

I. Property, Plant and Equipment (Parent)

Property, plant and equipment are initially stated at cost and then depreciated on a straight line basis. Land and buildings are stated at valuation as determined by an independent registered valuer. The basis of valuation of the land and buildings is highest and best use. Revaluation surpluses are taken directly to the revaluation reserve. Decreases in value are debited directly to the revaluation reserve to the extent they reserve previous surpluses and are otherwise recognised as expenses (and income on subsequent reversal) in the statement of financial performance. The estimated useful lives of fixed assets are as follows:

Land	Indefinite
Buildings	30–40 years
Furniture and fittings	3–15 years
Office equipment	3–8 years
Motor vehicles	5–8 years

J. Property, Plant and Equipment (Group)

Property, plant and equipment are initially stated at cost and then depreciated using maximum rates approved for taxation purposes. The rates and method applied are as follows:

Furniture and fittings	11.4% – 18.0% diminishing value
Office equipment	22.0% – 60.0% diminishing value
Motor vehicles	7.5% diminishing value
Other assets	48.0% diminishing value

K. Investments with Fund Managers

Investments with fund managers are stated at market value. Realised and unrealised gains or losses on holding these investments are recognised in the statement of financial performance. These gains or losses are shown in the statement of financial performance as income from revaluation of investments.

L. Other Investments

Cash investments are stated at cost plus interest credited or accrued to balance date.

M. Accounts Receivable

Accounts receivable are stated at expected realisable value.

N. Rental Payments

Invest South Limited Group leases its premises in addition to certain items of plant and equipment. Operating lease payments, where the lessors effectively retain substantially all the risks and benefits of ownership of the leased items, are included in the determination of the operating surplus/(deficit) in equal instalments over the lease term.

O. Loan Funding Advances

Invest South Limited (a subsidiary) has advanced monies to non-related entities as part of its core business activity. Interest is charged on these advances and accrued where necessary. The investments are recorded at expected realisable value.

P. Impairment

If the estimated recoverable amount of an asset is less than its carrying amount, the asset is written down to its estimated recoverable amount and an impairment loss is recognised in the statement of financial performance.

Q. Grants

Grants are recognised when they are approved by the trustees. Unpaid grants are recorded as a liability.

R. Goods and Services Tax

The parent is not registered for goods and services tax. The parent financial statements are prepared using GST inclusive accounting. The subsidiary of Invest South Limited Group is registered for GST and all assets and liabilities have been stated exclusive of GST with the exception of receivables and payables which are stated inclusive of GST.

S. Income Taxation

From 1 April 2004, section CB4(1)(m) of the Income Tax Act 1994, exempts the trust from income tax. Invest South Limited Group follows the income taxes payable method for accounting for income tax.

T. Statement of Cash Flows

Operating cash flows includes interest and dividends paid or credited to investment funds under management. Cash movements in funds invested are recognised in investing activities.

U. Inventories

Stock and work in progress are stated at the lower of cost and net realisable value. Cost is determined on a first in, first out basis (or weighted average cost method).

V. Changes in Accounting PoliciesNon Current Grants Committed but not Paid

The group has changed its accounting policy for non-current grants committed but not paid to comply with FRS-15: Provisions, Contingent Liabilities and Contingent Assets.

Grants Recognised as an Expense

The group has changed its accounting policy for treatment of grants. In the current year they are recognised as an expense, instead of as a distribution. This is consistent with the statement of concepts.

Other Changes

With the exception of the above changes in accounting policies, accounting policies have been applied on a consistent basis with those to the previous year.

W. Changes to Comparatives

Certain comparatives have been changed to give a more meaningful comparison.

Notes to the Financial Statements for the Year Ended 31 March 2007**1. Operating Revenue**

	Note	2007 Group	2006 Group	2007 Parent	2006 Parent
Bad debts recovered		(113,594)	48,249	–	–
Change in value of investments		(685,612)	28,711,436	(685,612)	28,711,436
Depreciation recovered		–	68,488	–	–
Dividends and distributions		5,111,039	6,435,932	5,087,335	6,412,069
Interest received		3,969,857	3,019,334	3,270,261	2,422,909
Lease income		–	4,083	–	–
Other revenue		27,890	41,473	–	–
Share of associates' earnings		21,300	8,807	–	–
		<u>8,330,880</u>	<u>38,337,802</u>	<u>7,671,984</u>	<u>37,546,414</u>

2. Expenditure

	Note	2007 Group	2006 Group	2007 Parent	2006 Parent
Audit fees	3	36,547	26,973	32,047	23,473
Communications		32,982	33,749	17,566	19,302
Depreciation		67,407	73,835	66,240	71,655
Directors' fees		57,500	70,000	–	–
Loss/(gain) on disposal of property, plant and equipment		(4,500)	158	(4,500)	–
Fund manager fees		955,755	892,103	955,755	892,103
General expenses		117,116	119,093	72,150	78,954
Insurance		23,232	20,238	17,244	14,212
Interest		79	91	–	–
Occupancy costs		23,759	23,817	23,759	23,817
Office expenses		27,308	22,218	27,308	22,218
Professional fees	4	165,639	177,838	120,882	148,435
Promotion, reporting and compliance expenses		127,806	76,582	109,566	68,865
Rent		–	–	–	–
Salaries and staff costs		465,766	396,521	323,212	262,252
Trustees' fees	5	201,433	204,876	201,433	204,876
Vehicle expenses		27,285	20,645	27,285	20,645
		<u>2,325,114</u>	<u>2,158,737</u>	<u>1,989,947</u>	<u>1,850,807</u>

3. Auditors' Remuneration

	2007	2006	2007	2006
	<i>Group</i>	<i>Group</i>	<i>Parent</i>	<i>Parent</i>
During the year the following amounts were paid to auditors:				
To Ward Wilson, the former group auditors, for audit work	26,138	19,385	21,638	15,885
To Ward Wilson, the former group auditors, for grants audits	6,383	3,791	6,383	3,791
To other auditors, for grants audits	4,026	3,797	4,026	3,797
	<u>36,547</u>	<u>26,973</u>	<u>32,047</u>	<u>23,473</u>

Audit fees are recognised on a cash basis – Deloitte were appointed auditors with effect from 1 April 2006.

4. Professional Fees

	2007	2006	2007	2006
	<i>Group</i>	<i>Group</i>	<i>Parent</i>	<i>Parent</i>
Financial/taxation advisory	92,202	114,930	92,202	114,930
Legal	50,251	33,562	5,494	4,159
Strategic review	–	18,828	–	18,828
	<u>142,453</u>	<u>167,320</u>	<u>97,696</u>	<u>137,917</u>

5. Trustees' Fees

Meeting fees and honorariums were paid to trustees as follows:

	<i>Meetings Attended</i>	<i>Parent 2007</i>	<i>Parent 2006</i>
A. A. Broad	62	38,290	38,945
P. B. Redpath	44	26,401	18,070
T. W. Harpur	44	16,125	17,000
F. G. Cardno (retired June 2005)	0	–	2,408
S. G. Palmer (retired June 2006)	8	3,758	20,605
N. J. Wyeth	45	18,870	21,600
D. Williams	42	20,700	22,600
M. Hawes	28	14,737	13,500
K. S. Henderson	38	17,070	14,935
G. M. Neave	36	16,555	20,230
J. T. Hicks (appointed June 2005)	29	14,270	14,983
P. Lindsay (appointed June 2006)	29	14,657	–
		<u>201,433</u>	<u>204,876</u>

Trustee fees and honorariums are set by the Minister of Finance.

6. Grants Approved

	2007	2006	2007	2006
	<i>Group</i>	<i>Group</i>	<i>Parent</i>	<i>Parent</i>
Grants approved this year	8,180,856	7,565,035	8,180,856	7,565,035
Less: Prior year's grants cancelled	(414,774)	(95,113)	(414,774)	(95,113)
Net grants approved	<u>7,766,082</u>	<u>7,469,922</u>	<u>7,766,082</u>	<u>7,469,922</u>

7. Taxation and Tax Free Distributions

The Taxation (GST, Trans-Tasman Imputation and Miscellaneous Provisions) Act 2003 amended the Income Tax Act 1994 to exempt the trust from income tax from 1 April 2004 and the trust is not required to prepare an income tax return beyond 31 March 2004. The trust can continue to make distributions to community organisations without an income tax liability.

8. Reserves

	2007	2006	2007	2006
	<i>Group</i>	<i>Group</i>	<i>Parent</i>	<i>Parent</i>
<i>(i) Capital Maintenance Reserve</i>				
Opening balance	12,990,499	1,284,664	38,031,734	1,284,664
Transfer from grants maintenance reserve	–	6,168,591	–	31,209,826
Transfer from statement of financial performance	4,827,366	6,168,561	4,827,366	6,168,561
Transfer to trust capital reserve	–	(631,317)	–	(631,317)
	<u>17,817,865</u>	<u>12,990,499</u>	<u>42,859,100</u>	<u>38,031,734</u>
<i>(ii) Grants Maintenance Reserve</i>				
Opening balance	25,159,499	8,059,332	1,633,895	10,058,421
Transfer to capital maintenance reserve	–	(6,168,591)	–	(31,209,826)
Transfer from statement of financial performance	(10,455,921)	23,268,758	(10,779,650)	22,785,300
	<u>14,703,578</u>	<u>25,159,499</u>	<u>(9,145,755)</u>	<u>1,633,895</u>
Total reserves	<u>32,521,443</u>	<u>38,149,998</u>	<u>33,713,345</u>	<u>39,665,629</u>

9. Trust Capital

Opening balance	158,460,000	158,460,000	158,460,000	158,460,000
Transfer from capital maintenance reserve	–	631,317	–	631,317
Grants paid from capital	–	(631,317)	–	(631,317)
	<u>158,460,000</u>	<u>158,460,000</u>	<u>158,460,000</u>	<u>158,460,000</u>

10. Accounts Receivable

Accounts receivable	218,047	110,749	157,781	25,479
Provision for doubtful debts	–	–	–	–
	<u>218,047</u>	<u>110,749</u>	<u>157,781</u>	<u>25,479</u>

11. Back Country Foods Limited

The advance to Back Country Foods Limited recorded in the group statement of financial position as at 31 March 2007, represents dividends paid to Invest South Limited by way of a credit to Invest South Limited's shareholder current account. The advance is interest free and repayable upon demand.

12. Loan Funding

As at 31 March 2007, the following issues are relevant regarding the current loan funding:

- The board of Invest South Limited has initiated legal proceedings against Enno Oudshoorn and Klaas Smak under the terms of the investors' agreement signed when Invest South Limited initially invested \$680,000 capital in Tulip International Limited. The agreement provides that in the event of default, Invest South Limited has the right to put the shares back to Enno Oudshoorn and Klaas Smak at original cost. Default occurred on the loan advanced to Tulip International Limited and the company was placed into receivership.
- Woodlands Apiary Limited have defaulted on their loan payments and on 8 May 2007, Invest South Limited exercised its power under the loan agreement and appointed John White as receiver.

	2007	2006
Investment in finance leases	249,148	249,148
Other advances	5,047,616	4,269,882
Total debt	<u>5,296,764</u>	<u>4,519,030</u>
<i>Represented by:</i>		
Current	1,212,656	751,038
Non current	4,084,108	3,767,992
Total debt	<u>5,296,764</u>	<u>4,519,030</u>

13. Loans

	2007	2006	2007	2006
Loan balances outstanding as at 31 March were as follows:	<i>Group</i>	<i>Group</i>	<i>Parent</i>	<i>Parent</i>
Troopers Memorial Corner Charitable Trust	195,000	195,000	195,000	195,000
Southland Museum and Art Gallery	–	14,115	–	14,115
Ringa Ringa Heights Golf Club	36,000	36,000	36,000	36,000
Croydon Aviation Museum	280,000	280,000	280,000	280,000
Tuatapere Hump Ridge Track	–	40,000	–	40,000
Invercargill Artificial Sports Surface Trust	96,500	96,500	96,500	96,500
Northern Southland Medical Trust	50,000	50,000	50,000	50,000
Otautau Community Health Trust	21,000	24,000	21,000	24,000
Troopers Memorial Corner Charitable Trust – Yule House	170,000	180,000	170,000	180,000
Southland Heritage Buildings Preservation Trust	–	25,000	–	25,000
Wyndham Rest Home	100,000	100,000	100,000	100,000
Parata Rest Home	15,000	15,000	15,000	15,000
Borland Lodge	331,641	311,400	331,641	311,400
Southland Indoor Leisure Centre Charitable Trust	800,000	–	800,000	–
	<u>2,095,141</u>	<u>1,367,015</u>	<u>2,095,141</u>	<u>1,367,015</u>

Each loan is repayable on demand. All loans are interest free, with the exception of the loan to Borland Lodge, which attracts interest of 6.5%.

14. Investment in Associates*(a) Carrying amount of associates*

Carrying amount at beginning of year	149,171	143,364	–	–
Equity accounted earnings of associates	21,300	8,807	–	–
Addition of associates	375,246	–	–	–
Dividends from associates	(3,000)	(3,000)	–	–
Disposal of associate	–	–	–	–
Carrying amount at end of year	<u>517,717</u>	<u>149,171</u>	<u>–</u>	<u>–</u>

(b) Equity accounted earnings of associates

Equity accounted earnings comprise:

Surplus/(deficit) before income tax	21,300	8,807	–	–
Amortisation of goodwill	–	–	–	–
Income tax	–	–	–	–
Net surplus/(deficit)	<u>21,300</u>	<u>8,807</u>	<u>–</u>	<u>–</u>

15. Reconciliation with Net Surplus

	2007 Group	2006 Group	2007 Parent	2006 Parent
Net surplus/(deficit) before distribution	6,141,539	36,275,924	5,817,810	35,792,466
Less: Grants	(11,770,094)	(7,469,922)	(11,770,094)	(7,469,922)
Net surplus/(deficit)	<u>(5,628,555)</u>	<u>28,806,002</u>	<u>(5,952,284)</u>	<u>28,322,544</u>
<i>Add/(less) movements in working capital items</i>				
Increase/(decrease) in accounts payable and accrued expenses	41,939	14,094	13,644	3,026
Increase/(decrease) in grants committed but not paid	(109,904)	(478,531)	(109,904)	(478,531)
(Increase)/decrease in accounts receivable	(107,297)	493,156	(132,302)	484,061
(Increase)/decrease in taxation refund due	–	1,379	–	–
	<u>(175,262)</u>	<u>30,098</u>	<u>(228,562)</u>	<u>8,556</u>
<i>Add/(less) non-cash items</i>				
Depreciation	67,407	73,677	66,240	71,655
Depreciation recovered	(4,500)	(68,488)	(4,500)	–
Increase/(decrease) in non-current grants committed	4,004,000	–	4,004,000	–
Revaluation of investments	685,612	–	685,612	–
Revaluation of property	(135,773)	(96,859)	(135,773)	(96,859)
Non cash interest income	(20,241)	–	(20,241)	–
Loan repayment by way of a grant approval	40,000	40,000	40,000	40,000
Share of associates earnings	(21,300)	(8,807)	–	–
	<u>4,615,205</u>	<u>(60,477)</u>	<u>4,635,338</u>	<u>14,796</u>
Net cash from operating activities	<u>(1,188,612)</u>	<u>28,775,623</u>	<u>(1,545,508)</u>	<u>28,345,896</u>

16. Grants Committed Not Paid

Commitments of \$4,004,000 exist for grants which will be distributed from either capital or future income sources in future years. Specific commitments are as follows:

	Parent 2007	Parent 2006
Croydon Aviation Museum	280,000	280,000
Deep Cove Outdoor Education Trust	15,000	–
Families First Trust	–	40,000
Gore & Districts St James Theatre Trust	400,000	–
Invercargill Repertory Society	20,000	–
Invercargill Student Support Network	1,144,000	–
Netball Southland	50,000	–
Queenstown Aquatic Centre	1,500,000	1,500,000
Queenstown Christian Camp	105,000	–
South Catlins Environment and Development Trust	250,000	500,000
Southland Indoor Leisure Centre Charitable Trust	–	80,000
Tuatapere Hump Ridge Track	–	40,000
University of Otago	240,000	–
Wakatipu Trails Trust	–	100,000
	<u>4,004,000</u>	<u>2,540,000</u>

The years in which these commitments fall due are as follows:

Year ending 31 March 2007	–	790,000
Year ending 31 March 2008	1,868,800	550,000
Year ending 31 March 2009	748,800	350,000
Year ending 31 March 2010	598,800	400,000
Year ending 31 March 2011	648,800	450,000
Year ending 31 March 2012	138,800	–
	<u>4,004,000</u>	<u>2,540,000</u>

Commitments of up to \$4,580,000 exist for loans which trustees have approved, but which had not been drawn down as at balance date. The approved loans are as follows:

	<i>Parent 2007</i>	<i>Parent 2006</i>
Arrowtown Community Pre-school	30,000	–
Awarua Social Services	200,000	200,000
Living Fiordland Charitable Trust	3,700,000	3,700,000
South Catlins Environment and Development Trust	600,000	600,000
Southland Indoor Leisure Centre Trust	–	800,000
Southern Rural Fire Authority	50,000	–
	<u>4,580,000</u>	<u>5,300,000</u>

At 31 March 2007, Invest South Limited had no commitments.

(2006: Invest South Limited had a commitment to pay the uncalled share capital of the 100%-owned company Invest South Asset Management Limited).

17. Property, Plant and Equipment

	<i>2007 Cost</i>	<i>2007 Accum depn</i>	<i>2007 Book Value</i>	<i>2006 Book Value</i>
<i>Parent</i>				
Land – at valuation	457,419	217,419	240,000	220,000
Buildings – at valuation	523,063	(56,937)	580,000	485,000
Office equipment	219,714	172,412	47,302	36,742
Furniture and fittings	154,250	144,801	9,449	14,230
Motor vehicles	116,483	59,267	57,216	51,663
	<u>1,470,929</u>	<u>546,962</u>	<u>933,967</u>	<u>807,635</u>
<i>Group</i>				
Land – at valuation	457,419	217,419	240,000	220,000
Buildings – at valuation	523,063	(56,937)	580,000	485,000
Office equipment	236,797	188,495	48,302	38,724
Furniture and fittings	157,770	147,194	10,576	15,591
Motor vehicles	116,483	59,267	57,216	51,663
Other assets	1,423	1,352	71	137
	<u>1,492,955</u>	<u>556,790</u>	<u>936,165</u>	<u>811,115</u>

Land and buildings have been revalued as at 31 March 2007 and are stated at their revalued amounts as determined by Chadderton Valuation, an independent registered valuer (a member firm of the New Zealand Institute of Valuers).

The original cost of land was \$457,419 and the original cost of the building was \$523,063.

18. Investments With Fund Managers

The parent has funds with five investment managers (fund managers), being Alliance Bernstein, AMP Asset Management, Capital International, ING (NZ) Limited and Tower Asset Management. Market values and asset allocations of these investments as at balance date were as follows:

	<i>Alliance Bernstein (NZ\$m)</i>	<i>AMP (NZ\$m)</i>	<i>Capital Intn'l (NZ\$m)</i>	<i>ING (NZ) (NZ\$m)</i>	<i>Tower Asset Mgmt (NZ\$m)</i>	<i>2006 Total (NZ\$m)</i>	<i>2005 Total (NZ\$m)</i>
NZ equities	–	–	–	21,000	–	21,000	24,130
Overseas equities	37,273	–	35,338	–	–	72,608	81,400
NZ fixed interest	–	23,510	–	–	–	23,510	24,320
Overseas fixed interest	–	–	–	–	50,233	50,230	46,920
Property	–	880	–	–	–	880	940
Cash	–	10,760	–	15,996	–	26,756	20,440
	<u>37,273</u>	<u>35,150</u>	<u>35,338</u>	<u>36,996</u>	<u>50,233</u>	<u>194,984</u>	<u>198,150</u>

Exposure to currency, interest rate and credit risk arises in the normal course of the fund managers' management of the group's investments. A range of hedging policies are in place whereby the fund managers use derivative financial instruments as a means of managing exposure to fluctuations in foreign exchange rates and interest rates. While these financial instruments are subject to the risk of market rates changing subsequent to acquisition, such changes would generally be offset by opposite effects on the items being hedged.

19. Group Investments

<i>Name</i>	<i>Ownership Interest Held</i>		<i>Balance Date</i>	<i>Principal Activity</i>
	<i>2007</i>	<i>2006</i>		
<i>Subsidiaries</i>				
Southland Community Trust Charities Limited	100%	100%	31 March	Distribution of grants to charitable organisations
Invest South Limited	100%	100%	31 March	Debt funding and equity investment
Invest South Asset Management Limited	–	–	31 March	Asset management

Associates

Back Country Foods Limited	42%	42%	31 March	Manufactures freeze dried prepared meals
Tulip International Limited	33%	33%	31 May	In receivership
Bush Road Limited	30%	0%	31 March	Processes and wholesales vegetables and associated products
Woodlands Apiary Limited (in receivership)	49%	0%	31 December	Manufactures and wholesales honey and associated products

20. International Financial Reporting Standards

In December 2002, the New Zealand Accounting Standards Review Board announced that the New Zealand International Financial Reporting Standards (NZ IFRS) will apply to all New Zealand reporting entities for the periods commencing on or after 1 January 2007. Entities have the option to adopt NZ IFRS for periods beginning on or after 1 January 2005. The trust has decided to adopt IFRS effective from 1 April 2008.

The trust has started to assess the key differences in accounting policies between NZ IFRS and current NZ GAAP with a view to determining the impacts on the financial statements that are expected to arise on transition. As the trust has not yet completed an analysis of the differences between existing NZ GAAP and NZ IFRS, it is unable to reliably estimate the key differences in accounting policies or quantify the impacts to the financial statements that are expected to arise on transition to NZ IFRS.

21. Segmental Information

The trust's specified area includes all of the areas of Invercargill City Council, Southland District Council, Gore District Council, the Heriot and Tapanui areas of Clutha District Council, and the Wakatipu Basin area of Queenstown Lake District Council. The trust's principal activities are to invest the trust capital, both within the specified area and outside of the region, and to distribute grants for charitable, cultural, philanthropic, recreational and other purposes being purposes beneficial to the community principally within the trust's specified area.

22. Financial Instruments*General*

The group states its investments in managed funds at estimated market value. The trustees consider that the fair value of the financial assets is identical to the value in the statement of financial position.

Concentration of Credit Risk

The group from time to time has significant funds in trading bank deposits. The group limits risk by spreading the deposits over several trading banks. The group has not required collateral or other security to support its financial instruments. The group further limits risk through its policy of placing investment funds with five separate fund managers, with each fund manager having an investment mandate which requires that they diversify their investments on the group's behalf. The group has sought and obtained the advice of professional financial advisors prior to making its investment allocation and placement decisions.

Interest Rate Risk

The bank deposits are sensitive to changes in interest rates, as are a proportion of the funds managed by the fund managers.

23. Related Parties

There were no related party transactions during the year (2006: Nil).

24. Subsequent Events

Following balance date, Invest South Limited received \$105,066 from Bush Road Limited, being a pro rata share repurchase. Invest South Limited has also appointed John White as receiver of Woodlands Apiary Limited as at 8 May 2007. The financial effects of these events have not been recognised in the financial statements.

(2006: There were no significant events of which readers of the financial statements need to be aware).

Audit Report***To the Trustees of the Community Trust of Southland***

We have audited the financial statements. The financial statements provide information about the past financial performance and financial position of the trust and the group as at 31 March 2007. This information is stated in accordance with the accounting policies set out.

Board of Trustees' Responsibilities

The board of trustees is responsible for the preparation, in accordance with New Zealand law and generally accepted accounting practice, of financial statements which give a true and fair view of the financial position of the Community Trust of Southland and group as at 31 March 2007 and of the results of operations and cash flows for the year ended on that date.

Auditors' Responsibilities

It is our responsibility to express an independent opinion on the financial statements presented by the board of trustees.

Basis of Opinion

An audit includes examining, on a test basis, evidence relevant to the amounts and disclosures in the financial statements. It also includes assessing:

- the significant estimates and judgements made by the board of trustees in the preparation of the financial statements;
- whether the accounting policies are appropriate to the trust's and group's circumstances, consistently applied and adequately disclosed.

We conducted our audit in accordance with New Zealand Auditing Standards. We planned and performed our audit so as to obtain all the information and explanations which we considered necessary in order to provide us with sufficient evidence to obtain reasonable assurance that the financial statements are free from material misstatements, whether caused by fraud or error. In forming our opinion, we also evaluated the overall adequacy of the presentation of information in the financial statements.

Other than in our capacity as auditor, we have no relationship with or interests in the Community Trust of Southland or any of its subsidiaries.

Unqualified Opinion

We have obtained all the information and explanations we have required.

In our opinion:

- proper accounting records have been kept by the Community Trust of Southland as far as appears from our examination of those records;
- the financial statements:
 - comply with generally accepted accounting practice in New Zealand; and
 - give a true and fair view of the financial position of the Community Trust of Southland as at 31 March 2007 and the results of its operations and cash flows for the year ended on that date.

Our audit was completed on 20 February 2008 and our unqualified opinion is expressed as at that date.

DELOITTE, Chartered Accountants, Dunedin.

(A list of all distributions of income and capital approved by The Community Trust of Southland during the year ended 31 March 2007 is available, on request, from the trust's office.)

gs2013

New Zealand Gazette 2008 Deadlines

Anzac Day, 25 April 2008

***New Zealand Gazette* Edition—1 May 2008**

Normal publishing deadlines will apply.

d2008

Index

- | | |
|---|---|
| <p>A</p> <p>Animal Products Act—
Animal products notices available: 1915</p> <p>B</p> <p>Bankruptcy Notices—
Bankruptcies: 1886
No asset procedures: 1886</p> <p>Building Act—
Appointments
Product certification accreditation body: 1908</p> <p>C</p> <p>Civil Union Act—
Lists of civil union celebrants: 1912</p> <p>Community Trusts Act—
Annual accounts
The Community Trust of Southland: 1922</p> <p>Companies Act—
Administrations
Swordfish Lodge Management Ltd.: 1895</p> <p>Amalgamation of companies
Provenco Group Ltd./Cadmus Technology Ltd.: 1907</p> <p>Cessation of business in New Zealand
Designware Consulting Pty Ltd: 1900
Somnio Pty Limited: 1900
Storwell Storage Systems Pty. Ltd: 1900</p> <p>Persons prohibited from managing companies: 1907</p> <p>Removals
Albert Navaho Ltd.: 1897
Alpine Properties Ltd.: 1896
Aspil Ltd.: 1896
Auckland City Lease Holdings Ltd.: 1888
Auckland City Lease Ltd.: 1888</p> | <p>B52 Holdings Ltd.: 1896
BBMFL Investments Ltd.: 1897
Beaver Shack Ltd.: 1896
Berakas Corporation Ltd.: 1896
Blockbusters Ltd.: 1896
Bristol Investments Ltd.: 1896
Broken Yellow Line Ltd.: 1896
BSR Ltd.: 1888
Bush Road Properties Ltd.: 1898
Cartledge Wool Exports Ltd.: 1899
Coffs - Kocass Pty Ltd: 1897
Equity Management Holdings Ltd.: 1898
GA Group Services Ltd.: 1898
Glenshera Ltd.: 1899
Hang Eleven Ltd.: 1899
Hollie Developments Ltd.: 1896
Livewell 2004 Ltd.: 1888
Midas Developments Solution Dynamics Ltd.: 1896
Namco Industries Ltd.: 1900
New Zealand Winemakers Centre Ltd.: 1899
P L Macpherson Holdings Ltd.: 1897
Pacific Properties (PS No.1) Ltd.: 1888
Perimac New Zealand Ltd.: 1896
Petrosian Enterprises Ltd.: 1897
Prado Construction Ltd.: 1898
PS Property Botany Downs Ltd.: 1888
PS Property Holdings Ltd.: 1888
PS Property New Lynn Ltd.: 1888
Quatro Construction Ltd.: 1898
Somerset Services Ltd.: 1899
Strand Fisk & Muldoon Ltd.: 1896
Top Laminators Ltd.: 1888
TRAL Investments Ltd.: 1897
Trans-pac Express Ltd.: 1898
TRCL Holdings Ltd.: 1897
Zanado Enterprises Ltd.: 1888</p> |
|---|---|

Removals lists: 1895

Winding up/liquidations

Allbanx Mortgages Ltd.: 1904
 Alstom New Zealand Ltd.: 1892
 Ambition Wholesalers Ltd.: 1895
 AMMA Corp Ltd.: 1907
 Ashby Holdings Ltd.: 1904
 Auckland City Lease Holdings Ltd.: 1888
 Auckland City Lease Ltd.: 1888
 B Q Holdings Ltd.: 1900
 Balmoral Homes Ltd.: 1894
 Benton Rede Ltd.: 1890
 Black Rocks Cafe and Bar Ltd.: 1890
 Broadbeach Group Ltd.: 1894
 BSR Ltd.: 1888
 Caprice Acquisitions Ltd.: 1901
 Cardno Television Productions Ltd.: 1906
 Cutting Edge (NZ) Ltd.: 1903
 D.J.R. Ltd.: 1906
 Dahomey Ltd.: 1891
 Devoted Vine Ltd.: 1906
 DJL Industries Ltd.: 1892
 Domani Group Ltd.: 1905
 Dotcard (Australasia) Ltd.: 1902
 EmbeddedFusion Ltd.: 1889
 Englefield Enterprises Ltd.: 1902
 Eventmakers International Ltd.: 1895
 Foxton Hotel Ltd.: 1890
 G W & S B Design & Marketing Ltd.: 1904
 Gary Smith Bricklayers Ltd.: 1905
 H4 Construction Ltd.: 1893
 Harvest Builders Ltd.: 1902
 Hong Kong Cuisine Cafe Ltd.: 1888
 Hope Island Holdings Ltd.: 1891
 IJ Contractors Ltd.: 1903
 Iso Vines Ltd.: 1888
 J W Lepper Ltd.: 1905
 Jaytech Intelligent Systems Ltd.: 1902
 Kiwi Viticulture Ltd.: 1906
 Livewell 2004 Ltd.: 1888
 London Traders Ltd.: 1892
 Lorraine Adams Design Ltd.: 1893
 Macron Holdings Ltd.: 1894
 Madison House Ltd.: 1892
 Madison Lifestyle Village Ltd.: 1892
 Merlot Homes Ltd.: 1902
 Monte Cecilia House Trust: 1903
 New Lynn Tyres & Car Repairs Ltd.: 1904
 New Zealand Power Construction Ltd.: 1902
 November Properties 1995 Ltd.: 1891
 NZ Reit Ltd.: 1892
 Office Elves Group Ltd.: 1901
 Orapiu Bay Resort Ltd.: 1904
 OVL Builders Ltd.: 1889
 Pacific Carwash Systems Ltd.: 1889
 Pacific Properties (PS No.1) Ltd.: 1888
 Papakura Liquor Ltd.: 1901
 Parnell Property Maintenance Ltd.: 1905
 Pedlars Recyclers Ltd.: 1891
 PJM Properties Ltd.: 1894
 Pretton Ltd.: 1906
 PS Property Botany Downs Ltd.: 1888
 PS Property Holdings Ltd.: 1888
 PS Property New Lynn Ltd.: 1888
 Pursuit Property No1 Ltd.: 1891
 Quick Freight Ltd.: 1901
 Richter Investments Ltd.: 1891
 Rojace Enterprises Ltd.: 1903
 Sawgrass Developments Ltd.: 1904
 Scotia Trustee Ltd.: 1903
 Shire Developments No 4 Ltd.: 1901
 SJG Construction Ltd.: 1894
 Southern Lakes Engineering Ltd.: 1907
 Suite Centre Ltd.: 1894
 Te Uki Tamariki Ou Cook Island Inc.: 1892
 The Jolly Engineer Ltd.: 1893
 Thunder Holdings Ltd.: 1890
 Top Laminators Ltd.: 1888
 Transport Repairs & Services 2002 Ltd.: 1890
 Transpread International Ltd.: 1901
 W.Scott/Morris Auto Electrical Ltd.: 1893
 Waimarie Aged Care Ltd.: 1893
 Waimarie Homecare Ltd.: 1893
 Waimea Tyres Ltd.: 1903
 Wairarapa Financial Services Ltd.: 1888
 Wanaka Gas Ltd.: 1894

Wayne Blake Builders Ltd.: 1905

Westway Quarry Ltd.: 1888

Wine Reach Services Ltd.: 1907

WXY Ltd.: 1889

Zanado Enterprises Ltd.: 1888

Conservation Act—

Land notices

Napier: 1917

F

Fair Trading Act—

Unsafe goods

Tian Mao water colour paint sets: 1908

Fisheries Act—

Fisheries notices

Seabird Sustainability Measures—Bottom Longlines

Revocation 2008/712: 1909

Food Act—

New Zealand Food Standards: 1915

H

Hazardous Substances and New Organisms Act—

Codes of practice

Approvals

Above Ground Tanks with Integral Secondary Containment:
1915

Honours and Awards—

Retention of the title 'The Honourable': 1908

J

Justices of the Peace Act—

Retirements: 1913

L

Land Notices—

Other Cities

Napier: 1920

Other Districts

Ruapehu: 1918

Waipa: 1919

Roading Cities

Hamilton: 1919

Napier: 1920

Tauranga: 1920

Roading Districts

Far North: 1918

Hurunui: 1921

Kaipara: 1919

New Plymouth: 1918

Otorohanga: 1919

Tasman District

Amendment 1984/4146: 1921

Whangarei: 1919

Land Transport Rule: Traffic Control Devices—

Pedestrian crossing warning lights trial extension: 1915

M

Marriage Act—

Lists of marriage celebrants: 1912, 1913

Marriage celebrants removed from list: 1913

Medicines Act—

Consent to the distribution of changed medicines: 1912

P

Private Schools Conditional Integration Act—

Supplementary integration agreements: 1909

Property Law Act—

Entry into possession of mortgaged property: 1908

R

Receiverships Act—

Appointment and release of receivers and managers

Advantage Construction & Consultancy Ltd.: 1887

Danben Holdings Ltd.: 1887

Regulations (Acts and Regulations Publication Act)—

Civil List (Annuities) Determination 2008 (SR 2008/91): 1922

Civil List Determination 2008 (SR 2008/90): 1922

Immigration (Transit Visas) Amendment Regulations 2008

(SR 2008/94): 1922

Limited Partnerships Act 2008 Commencement Order 2008

(SR 2008/92): 1922

Limited Partnerships Regulations 2008 (SR 2008/93): 1922

Reserves Act—

Land notices

Grey

Corrigendum 2008/1828: 1921

Hastings: 1918

Porirua: 1921

S

Securities Markets Act—

Authorised futures dealers: 1916

Sentencing Act—

Confiscation of motor vehicles: 1914, 1915